



# Xtend 13" Installation and Parts Manual

Not applicable to Meridian 13".

May 21/2026

## Table of Contents

Introduction	3
Safety	4
Installation	6
Operation	7
Parts Drawings	9
Maintenance	20
Winch Mounts	21

---

# Introduction

The Rodono Xtend swing auger is designed to replace the existing swing auger on many different augers manufactured today and in the past. It provides the freedom to drive hopper bottom trailers into place with the intake hopper retracted. The intake hopper may be extended under the trailer under operator control safely and with ease once the trailer is stopped. The Xtend auger is available in 10", 13", 14" and 16" models. The mounting ring is specific to the type of auger that the Xtend is added to. Please be familiar with the operation and safety instructions of your specific auger before adding an Xtend auger to it. This manual is only relevant to the Xtend auger and does not replace or supercede the auger manufacturers instructions.

The specifications for the different models can be found on our website at [www.rodono.ca](http://www.rodono.ca). This equipment can be added to several different manufacturers augers, many of which have had many changes over the years. We try and cover all the possible configurations, but if your installation does not match the documentation please contact us so that we can ensure your equipment will function properly.

## SAFETY

Safety is the protection of YOU and the people around you. Do not take risks with your life or others around you. Be certain that everyone operating this equipment is familiar with the recommended operating and maintenance procedures and follows all the safety precautions. Do not risk injury or death by ignoring good safety practices.

Most accidents can be prevented.

The safety symbols and warnings used throughout this manual and on the equipment are specified by the ASABE in specifications related to all farm equipment and specifically portable grain augers. These warnings are meant to make you aware of risks to you. Please understand what they mean and pay attention.



### CAUTION

The caution symbol indicates a potentially hazardous situation that, if not avoided, may result in minor or moderate injury. It may also be used to alert against unsafe practices.



### WARNING

The Warning Symbol indicates a potentially hazardous situation that, if not avoided, could result in death or serious injury, and includes hazards that are exposed when guards are removed. It may also be used to alert against unsafe practices.



### DANGER

The Danger Symbol indicates an imminently hazardous situation that, if not avoided will result in death or serious injury. This signal word is to be limited to the most extreme situations, typically for machine components that, for functional purposes, cannot be guarded.

If for any reason a warning label is damaged, missing or unreadable it is the responsibility of the operator or machine owner to order new ones which must be available from the manufacturer. This applies to the main equipment as well as additions. Please do not hesitate to contact us for new labels.

## Decal and Label Locations

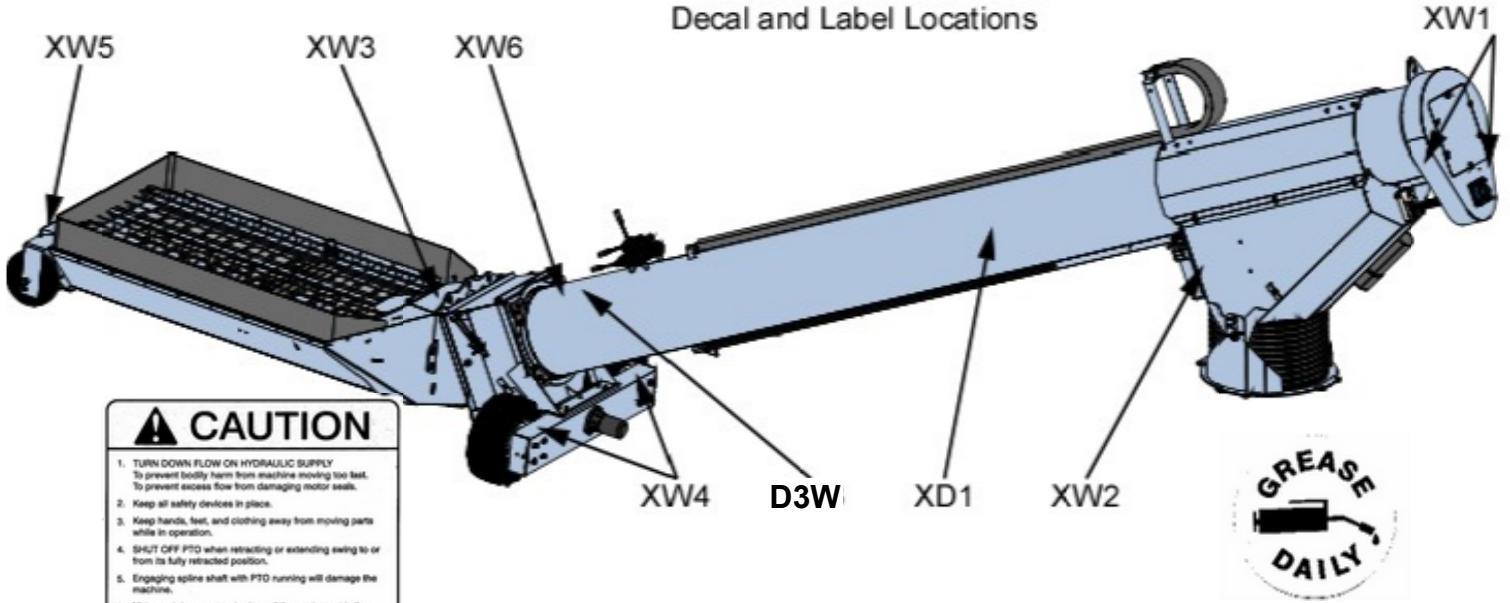

XW6 - Caution Decal



XWG - multiple locations

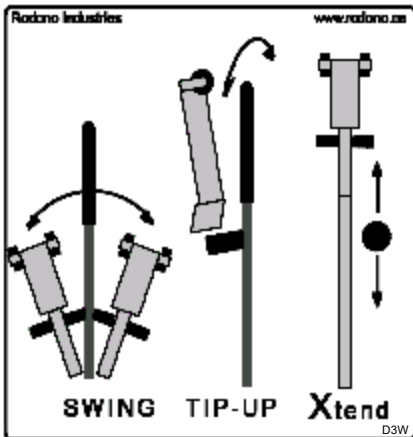

D3W - Hydraulic Control Decal

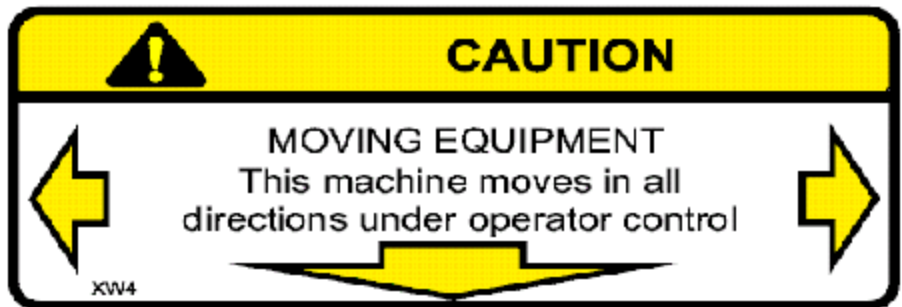

XW4 - Moving Equipment Warning



XW5 - Danger Missing Shield



XW2 - Rotating Part Warning



XW1 - Rotating Part Warning



XW3 - Rotating Flighting Warning



XD1 - Branding Decal

## Installation:

- 1: Swing your old swing auger into a position out from the side of your auger that is safe to lift.
- 2: Secure an appropriate lifting device with appropriate lifting straps or chains to your old swing.
- 3: apply slight tension to prevent swing from falling when the fasteners are removed.
- 4: Remove the bolts and washers that hold swivel ring of your old swing unit down to the auger deck. Keep the parts for use on your new Xtend Swing.
- 5: Usually the lower half of the U-Joint that connects the swing auger to main auger is splined and should slip up as the swing auger is lifted. If the spline is seized (usually due to running fertilizer through the auger) then it may have to be pried off, and sometimes heating is necessary. Lift the old swing auger off the main auger deck in a safe manner.
- 6: The center of the U-Joint needs to be aligned with the swivel between the ring and the lower spout of the Xtend swing auger. Check the height from the bottom of the ring you removed to the pivot pin in the ring. This height should match the height on the ring supplied with the Xtend swing. If it does not, please contact Rodono Industries to discuss the issue.
- 7: In most cases the U-Joint can be taken off the old swing and put on the new Xtend swing. The center of the u-joint must be placed in line with the swivel. This can be done by measuring the height above the ring with a straight edge across the bottom of the ring. The pivot bolt and center of cross (Or center section of double) should be inline. You can take one of the swing bolts out and look through the hole in the bushing and see if the u-joint bearing is in line with the pivot. If you are sure it is in line you can lock it in place on the upper shaft.
8. The Xtend swing can be lowered into place on the main auger using the same lift system that you lifted the old one off. Grease the lower spline before lowering the auger. The u-joint can be aligned through the door on the in the side of the collector. Lower the Xtend auger into place.
9. The bolts and washers can be put back in place to hold the ring down. If they are adjustable, there should be clearance between the ring and the bushing on the bolts so that the ring is free to turn and shift a small amount if necessary.

## Operation:

The Xtend Swing auger adds two functions to a normal swing auger.

- 1: The ability to extend and retract.
  - 2: The ability to tilt the end of the hopper up or down.
- This allows the machine to either extend or swing.

The swing auger also has power swing.

All controls for these functions are conveniently located at the end of the swing tube where the operator has easy access to the handles on the trailer for opening the chute gates.

The controls are clearly identified on the label by the controls (Shown Below)

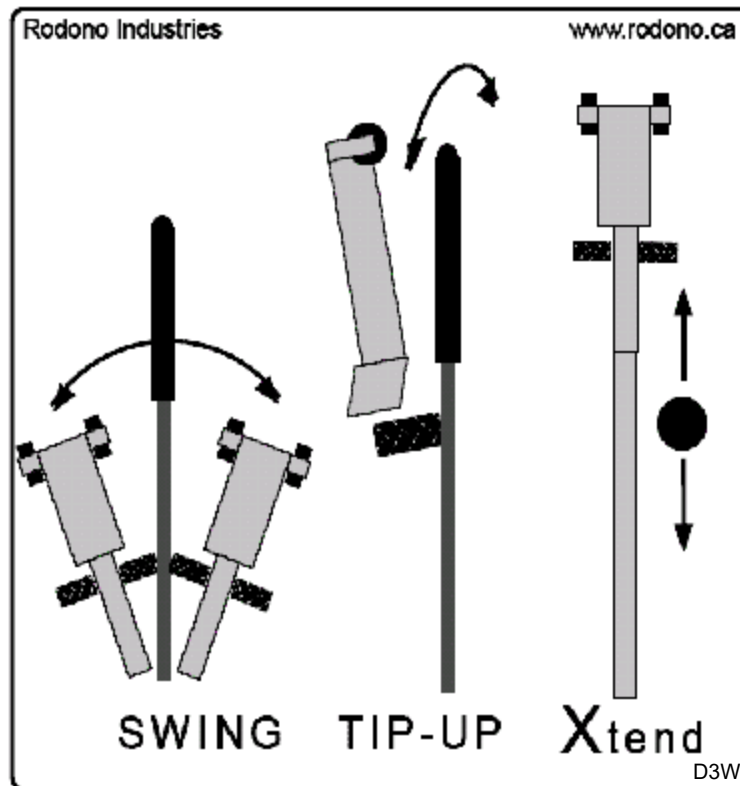

## Notes on hydraulics and capacity

**The tractor hydraulic flow to this unit should be turned down.** This will help prevent damage to the equipment and the operator. The flow should be turned down to the point where the operator is comfortable with the swing speed and the retraction speed while holding onto the controls.

As with all swing augers. It is possible for the swing to overfeed the main auger if the main auger is approaching or exceeding its maximum angle. The auger capacity drops significantly with increased angle. Whereas the angle on the swing changes very little in comparison, so it is possible for the swing to overfeed the main auger.

## Order of Operations

- 1: Lower swing from transport, Swing around to an appropriate unloading position. Roughly perpendicular to auger. (The only limitation to placement is that clear retraction should be possible without hitting your tractor cab)
  - 2: Retract Xtend auger all the way.
  - 3: Drive truck in so that you are roughly 2 feet from the end of the hopper and stop roughly between the appropriate hoppers.
  - 4: Extend hopper under trailer (With Tip Down)
  - 5: Raise hopper tip slightly off the ground and swing to position roughly centered below appropriate chute.
  - 6: Lower hopper tip onto ground
  - 7: ENGAGE PTO on tractor or power unit.
  - 8: Unload until empty and close chute
  - 9: Raise hopper tip
  - 10: Swing to other chute.
  - 11: Lower hopper tip onto ground.
  - 12: Unload until empty and close chute.
  - 13: DISENGAGE PTO on tractor or power unit.
  - 12: Retract Xtend auger fully.
  - 13: Move next trailer or truck into place as appropriate.
- Back to Step 4.

The Xtend auger may be swung or retracted freely with the PTO running as long as the spline shaft at the top does not become disengaged. On the 13" Xtend there is 20" of free movement back from full extension. The end of free working travel is indicated by the "Rodono Xtend" Decal starting to disappear under the collector cover.

## Xtend 13"

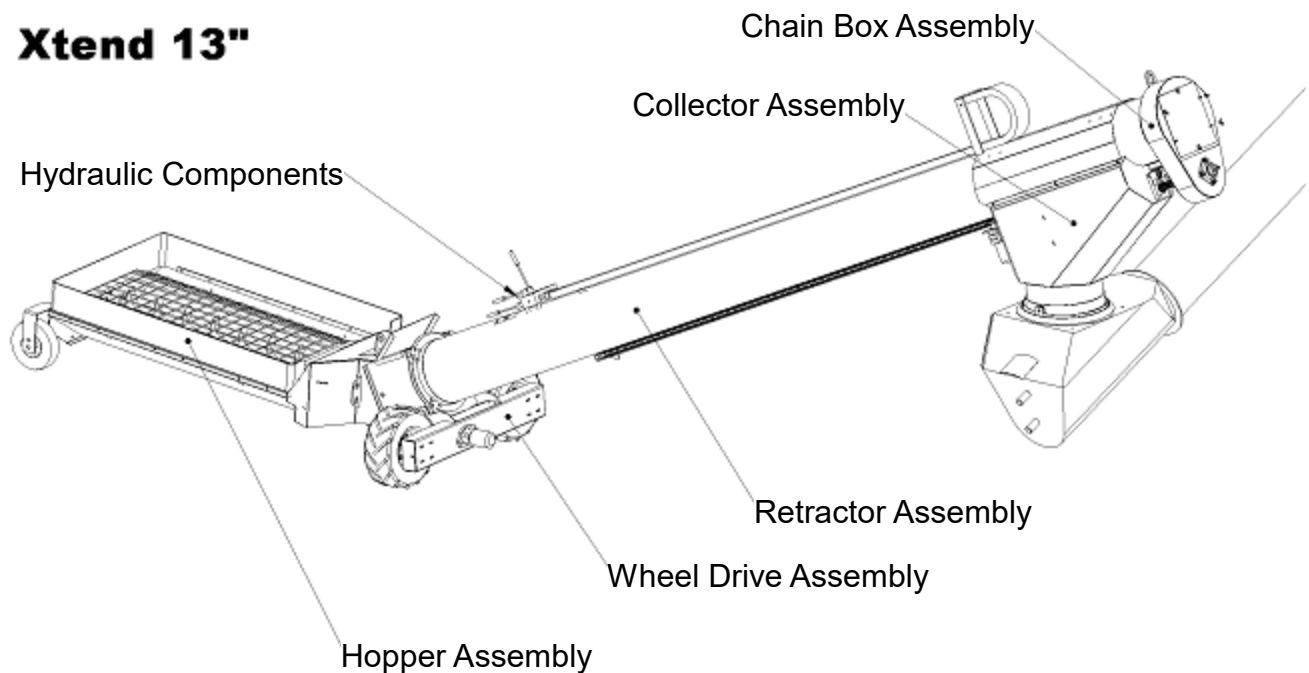

## R13-A100 Retractor Assembly

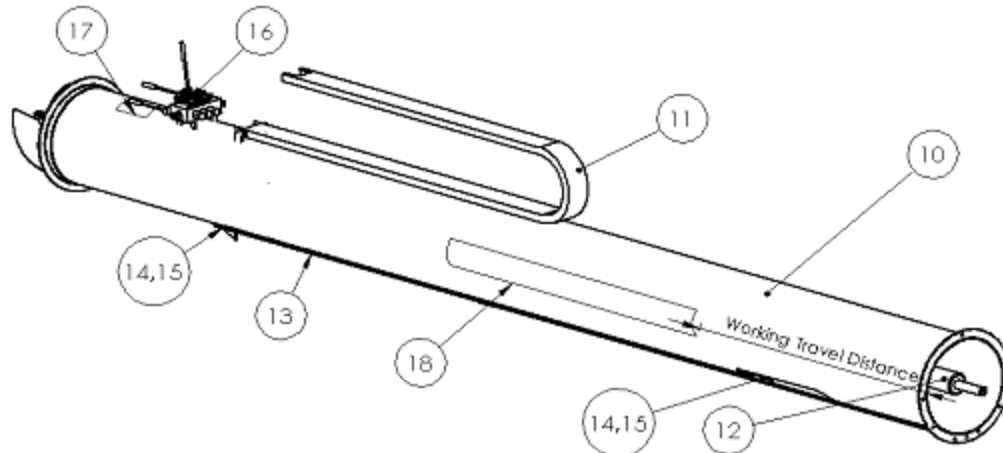

Item	Qty	Part #	Description
0	1	R13-A100	Complete Retractor Assembly
10	1	R13-A101	Welded Retractor
11	12'	IG200-10-125	Hose Carrier Chain
	4	H5CZ14.012	1/4" NC x 1/2" Bolt
	4	H5CZ14.034	1/4" NC x 3/4" Bolt
	4	LWZ14	1/4" Lock Washer
	4	NHCZ14	1/4" Nut
	1	IG2000-20	Carrier Bracket
	1	IG2000-21	Carrier Bracket
12	1	R13-A20	Main Screw Assembly
13	1	CHA 60-120.75	Rack Chain

Item	Qty	Part #	Description
14	2	CHA 60-1R-CO	Connecting Link
15	2	RP-2	Sliding Tightener
	2	H8CZ516.214	5/16" NC x 2 1/4" Gr 8 Bolt
	2	NH8CZ516	Nut 5/16" NC Gr 8
16	1	RC-A2	3 Spool Valve with fittings
	3	H5CZ516.214	5/16" x 2 1/4" NC Grade 5 Bolts
	3	SLCC516	5/16" NC Stover Lock Nut
17	1	D3W	Valve Label
	1	XW6	Caution Decal
18	2	XD1	Branding Decal
Notes			See Hydraulic Assembly for Valve Fittings

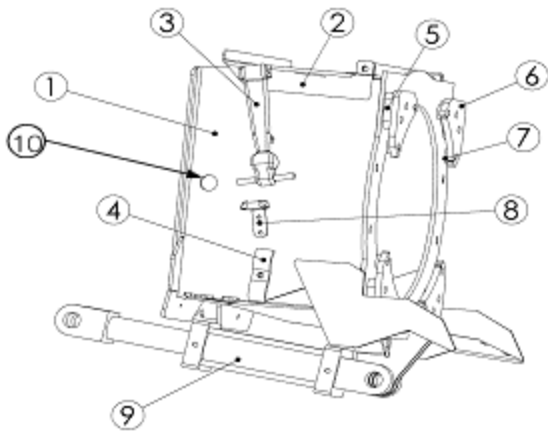

7	8	BW1-195	Wear Button
8	2	WJ208	Hood Latch Catch
	4	MPPS1024.58	Stainless Machine Screw
	4	LN18.81024	Nylon Lock Nut
9	1	25TL03-112	3" Stroke Tie Rod Cylinder
10	2	B75-100	Transition Box Pivot Bushing
	2	H5CZ34.112	Bolt 3/4" x 1.5"
	4	FWZC34	3/4" Flat Washer
	2	LNC34	3/4" Nylon Lock Nut

Item	Qty	Part #	Description
0	1	R13-A800	Retractor Box Assembly 2009-2024
1	1	R13-A801	Welded Box Assem 2009-2024
0	*	R13-A900	2025 Start SN 25D001
1	*	R13-A901	2025 Start SN 25D001
2	1	H13-A508	Transition Lid Assembly
	2	H5CZ38.1	Bolt 3/8" x 1 NC
	2	LNC38	Nylon Lock Nut 3/8"
	4	FWSAEZC38	SAE Flat Washer 3/8"
3	2	WJ208	Rubber Hood Latch
4	1	HC-1	Hose Clamp 2 Place
	1	H5CZ516.114	5/16" NC x 1 1/4" Bolt
	1	LNC516	Nylon Lock Nut 5/16" NC
5	4	R16-45	SwivelSpacerBlock
6	4	R16-534	LargeFlangeHolder
	8	H8CZ38.134	3/8" NC x 1 3/4" GR8 Bolt
	8	NH8CZ38	3/8" NC Nut Gr 8
	8	FW838	3/8" SAE Gr 8 Flat Washer
	8	LW838	3/8" Gr 8 Lock Washer

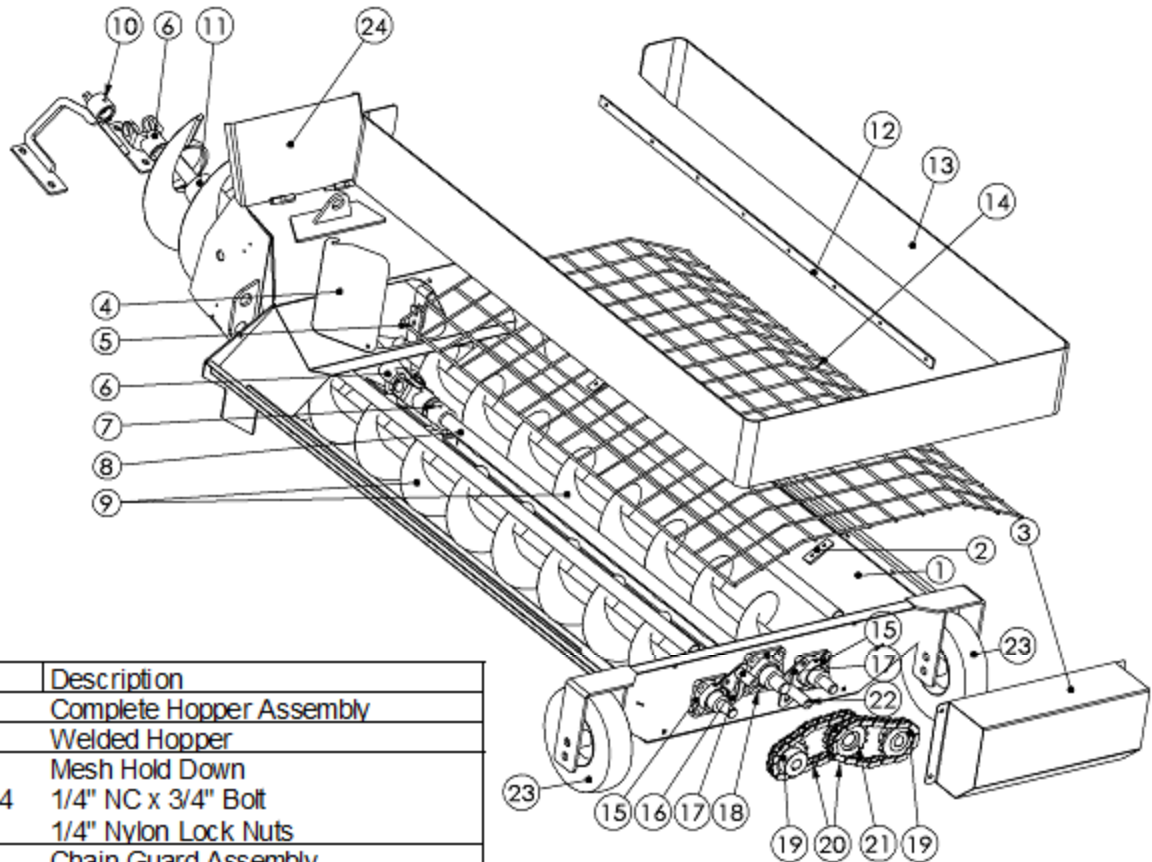

Item	Qty	Part #	Description
0	1	H13-A0	Complete Hopper Assembly
1	1	H13-A1	Welded Hopper
2	4	HC-4	Mesh Hold Down
	4	H5CZ14.034	1/4" NC x 3/4" Bolt
	4	LNC14	1/4" Nylon Lock Nuts
3	1	H10-21	Chain Guard Assembly
	4	NWCZ516	5/16" Wing Nut
4	1	HC-36	Transition Inspection Cover
	1	LNC516	5/16" Nylon Lock Nut
	1	FWZC516	Flatwasher USS 5/16"
	1	NWCZ516	5/16" Wing Nut
5	1	H13-A3	Feed Screw Bushing Hanger 13
	1	B100-125-150	Bronze Bushing
	1	H13-A3	Feed Screw Bushing Hanger 13
	1	B100-125-150	Bronze Bushing
	4	H5CZ38.114	Bolt 3/8" NC x 1 1/4"
	4	NHCZ38	Nut 3/8" NC
	4	FWSAEZC38	Flatwasher SAE 3/8"
	4	LWZ38	Lockwasher 3/8"
6	2	UA800-1220	U-Joint Assembly
	4	K14-15	Key 1/4" x 1 1/2"
7	1	H13-A33	Jack Shaft Bushing Assembly
	2	NHCZ38	Nut 3/8" NC
	2	FWSAEZC38	Flatwasher SAE 3/8"
	2	LWZ38	Lockwasher 3/8"
8	1	H13-27	Hopper Jack Shaft
9	2	H1-A3	Feed Screw Assembly
10	1	H13-A2	Upper Transition Bushing Support
	1	B125-150-150	Bronze Bushing
	4	H5CZ12.114	Bolt 1/2" NC x 1 1/4"
	4	FWSAEZC12	Flatwasher SAE 1/2"
	4	LNC12	Nylon Lock Nut 1/2" NC
11	1	H13-A22	Transition Screw Assembly
12	2	H13-56	Skirt Retainer
	8	H5CZ14.034	1/4" NC x 3/4" Bolt
	8	LWZ14	Lockwasher 1/4"
	8	NHCZ14	Nut 1/4" NC

Item	Qty	Part #	Description
13	1	H13-55	Skirt
14	1	H13-MESH	Mesh
15	2	F205-16G	Bearing Assembly
	4	H5CZ716.114	Bolt 7/16" NC x 1 1/4"
	4	H5CZ716.112	Bolt 7/16" NC x 1 1/2"
	8	LWZ716	Lockwasher 7/16"
	8	NHCZ716	Nut 7/16" NC
16	2	H13-54	Chain Tensioner Bracket
17	1	PT18B8L225	Chain Tensioner
	1	CBZ12.312	Carriage Bolt 1/2"NC 3 1/2"
	1	FWSAEZC12	Flatwasher SAE 1/2"
	1	LNC12	Nylon Lock Nut 1/2" NC
18	1	F206-20G	Bearing Assembly
	4	H5CZ716.112	Bolt 7/16" NC x 1 1/2"
	4	LWZ716	Lockwasher 7/16"
	4	NHCZ716	Nut 7/16" NC
19	2	WH16-SP6016X	Hub and Sprocket
	2	K25-125	Key 1/4" x 1"
20	2	CHA 60-21.75	Chain #60 x 21 3/4"
	2	CHA 60-1R-CO	Connecting Link
21	1	WDH20-SP6016X	Hub with Double Sprocket
	1	K25-125	Key 1/4" x 1 1/2"
22	1	PT18B8L278	Chain Tensioner
	1	CBZ12.4	Carriage Bolt 1/2"NC 4"
	1	FWSAEZC12	Flatwasher SAE 1/2"
	1	LNC12	Nylon Lock Nut 1/2" NC
23	2	WS10x4	Solid Wheels
	2	H5CZ34.512	Bolt 3/4" NC x 5 1/2"
	2	LNC34	Nylon Lock Nut 3/4" NC
24	1	H13-A8	Transition Cover Assembly

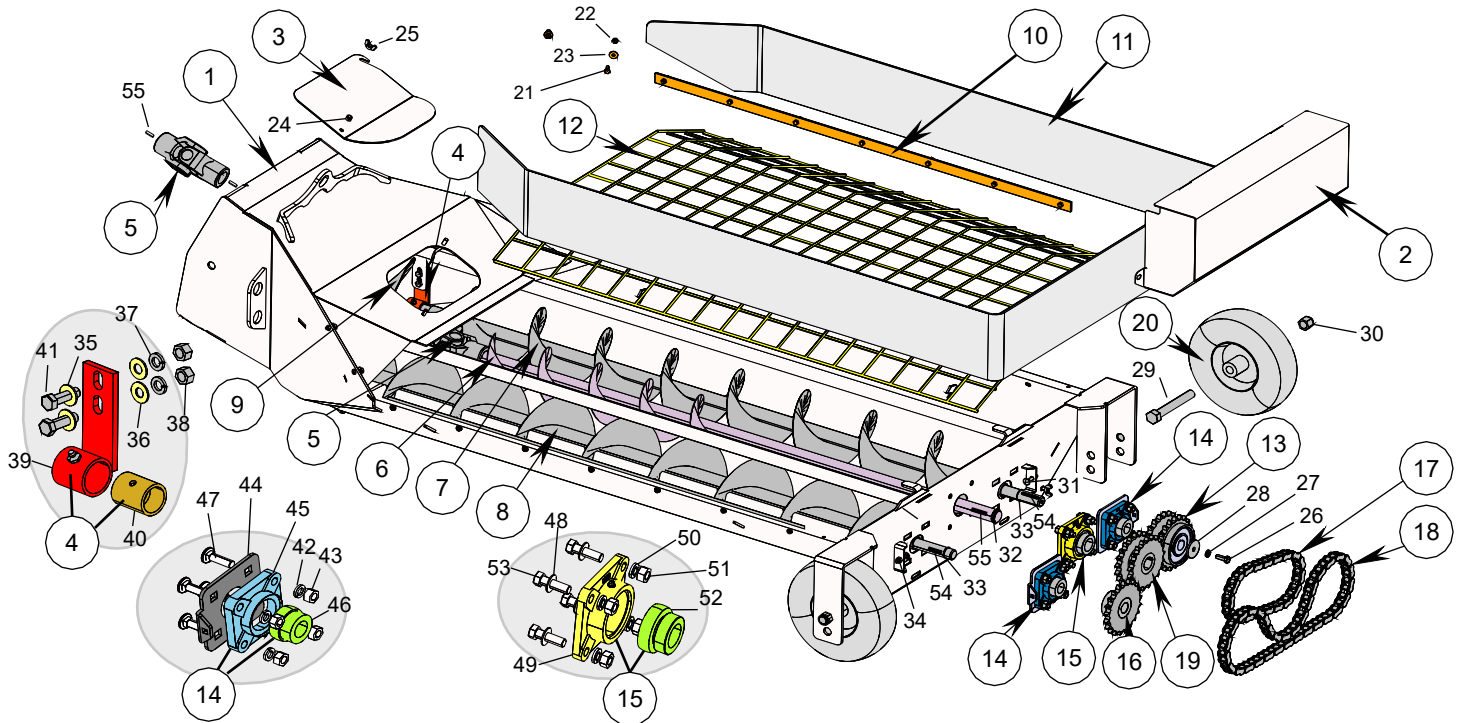

Item	Qty	Part #	Description
0	1	H13-A800	Complete Hopper Assem 2015-2024
0	1	H13-A900	Complete Hopper Assem 2025+
1	1	H13-A801	Welded Hopper 2015-2024
1	1	H13-A901	Welded Hopper 2025+
2	1	H13-521	Chain Guard Assembly
25	2	NWCZ516	5/16" Wing Nut
3	1	HC-36	Transition Inspection Cover
24	1	LNC516	5/16" Nylon Lock Nut
24	1	FWSAEZ516	Flatwasher SAE 5/16"
25	1	NWCZ516	5/16" Wing Nut
4	2	H13-A3	Feed Bushing Assem L&R
40	2	B100-125-150	Bronze Bushing
41	4	H5CZ716.114	Bolt 7/16" NC x 1 1/4"
38	4	NHCZ716	Nut 7/16" NC
35	8	FWSAEZC716	Flatwasher SAE 7/16"
37	4	LWZ716	Lockwasher 7/16"
5	2	UA800-1220	U-Joint Assembly 12 series 1 1/4"
55	4	K25-125	Key 1/4" x 1 1/4"
6	1	H13-527	Hopper Jack Shaft with flighting
7	1	H13-503R	Feed Screw Assem RH w/Groove
8	1	H13-504L	Feed Screw Assem LH w/Groove
33	2	SE-100-040	Snap Ring External 1"
9	1	H13-A505	Transition Screw Cartridge Assem *See Details Next Page
10	2	H13-56	Skirt Retainer
21	22	H5CZ14.034	1/4" NC x 3/4" Bolt
23	8	FWZC14	Flat Washer USS 1/4"
22	22	SLCC14	Stover Lock Nut 1/4" NC
11	1	H13-655	Skirt
12	1	H13-MESH	Mesh
13	1	WDI16H-21T	Idler Sprocket Assembly

Item	Qty	Part #	Description
28	1	W0375-175	Heavy Flat Washer 3/8" x 1.75"
27	1	LW838	Gr 8 Lockwasher 3/8"
26	1	H8FZ38.1	Bolt Gr 8 3/8" NF x 1"
14	2	F205-16G	Bearing Assembly
45	1	F205	Bearing Housing F205
46	1	SA205-16G	Bearing 1 w/ Locking Collar
44	2	H13-78	Sliding Chain Tensioner Plate
47	8	CBZ716.112	Carriage Bolt 7/16" NC x 1 1/2"
42	8	LWZ716	Lockwasher 7/16"
43	8	NHCZ716	Nut 7/16" NC
31	2	CBZ516.112	Carriage Bolt 5/16" NC 1 1/2"
34	2	LNC516	Nylon Lock Nut 5/16" NC
15	1	F206-20G	Bearing Assembly
49	1	F206	Bearing Housing F206
52	1	SA206-20G	Bearing 1 1/4" w/ Locking Collar
53	4	H5CZ716.112	Bolt 7/16" NC x 1 1/2"
48	4	FWZC716	Flat Washer 7/16"
50	4	LWZ716	Lockwasher 7/16"
51	4	NHCZ716	Nut 7/16" NC
16	1	WH16-SP6021X	Hub and Sprocket
54	2	K25-125	Key 1/4" x 1 1/4"
17	1	CHA 60-28.5	Chain #60 x 28 1/2"
17	1	CHA 60-1R-OF	Offset Connecting Link
17	1	CHA 60-1R-CO	Connecting Link
18	1	CHA 60-44.5	Chain #60 x 44 1/2"
18	1	CHA 60-1R-CO	Connecting Link
19	1	WDH20-SP6021X	Double 21 T Sprocket 1 1/4" Bore
55	1	K25-125	Key 1/4" x 1 1/4"
32	1	SE-125-050	Snap Ring 1 1/4"
20	2	WS10x4	Solid Wheels
29	2	H5CZ34.512	Bolt 3/4" NC x 5 1/2"
30	2	LNC34	Nylon Lock Nut

H13-A800 and H13-A801 are obsolete, Can be replaced by H13-A900 and H13-A901  
However a matching transition box will be required. Internal Parts are interchangeable.

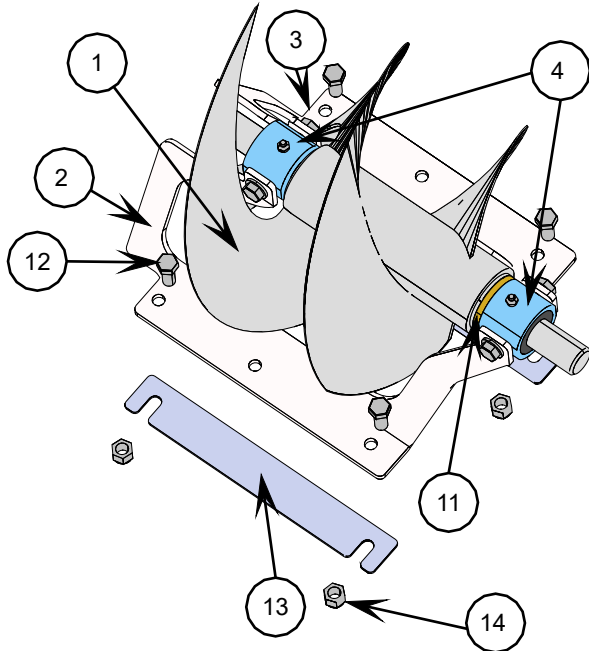

9: H13-A505 Transition Screw Cartridge Assembly

Item	Qty	Part #	Description
9	1	H13-A505	Transition Screw Cartridge Assem
1	1	H13-A122	Transfer Screw Assembly
2	1	H13-542	Transition Bushing Support Left
3	1	H13-543	Transition Bushing Support Right
4	1	H13-A503	Transition Bushing Assembly
11	1	H13-576	Bronze Thrust Washer
12	6	H5CZ12.114	Bolt 1/2" NC x 1 1/4"
13	2	H13-541	Shim (800 Series Hopper)

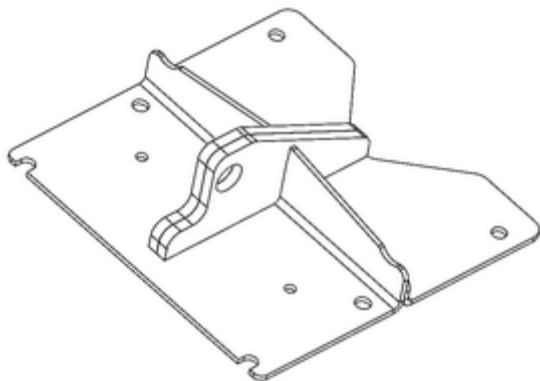

Item	Qty	Part #	Description
1	1	H13-A400	Bolt On Cylinder Mount
2	2	H5CA38.1	Grade 5 3/8" x 1" Locating Bolts
2	2	LNC38	Transition Bushing Support Left
3	1	H13-543	Nylon Lock Nut 3/8"

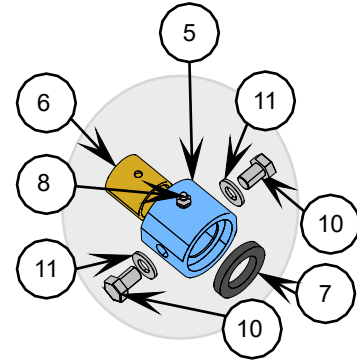

4: H13-A503 Transition bushing Assembly

Item	Qty	Part #	Description
4	2	H13-A503	Transition Bushing Assembly
5	1	B510-1.5	Bushing Holder
6	1	B125-150-150	Bronze Bushing 1 1/4" ID x 1.5" OD
7	1	SEA 471766	Seal (CR 12458)
8	1	GF 610	Grease Fitting
10	2	H8CZ12.034	Bolt 1/2" NC x 3/4" Gr8
11	2	NLM12	Anti-Vibe Lock Washer 1/2"

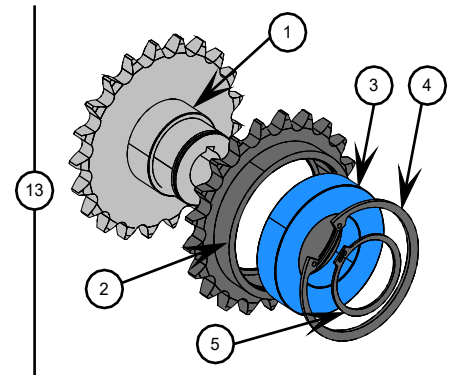

13: WDI16H-21T Idler Sprocket Assembly

Item	Qty	Part #	Description
0	1	WDI16H-21T	Drive and Idler on 1 in Hub
1	1	WDI16-632	Drive and Idler Hub
2	1	WDI-732	Idler Sprocket Machined
3	1	6210-2RSC3	High Speed Bearing for Double Idler
4	1	SEM-50-200	External Snap Ring 50mm
5	1	SIM-90-300	Internal Snap Ring 90mm

## C13-A0 Collector Assembly

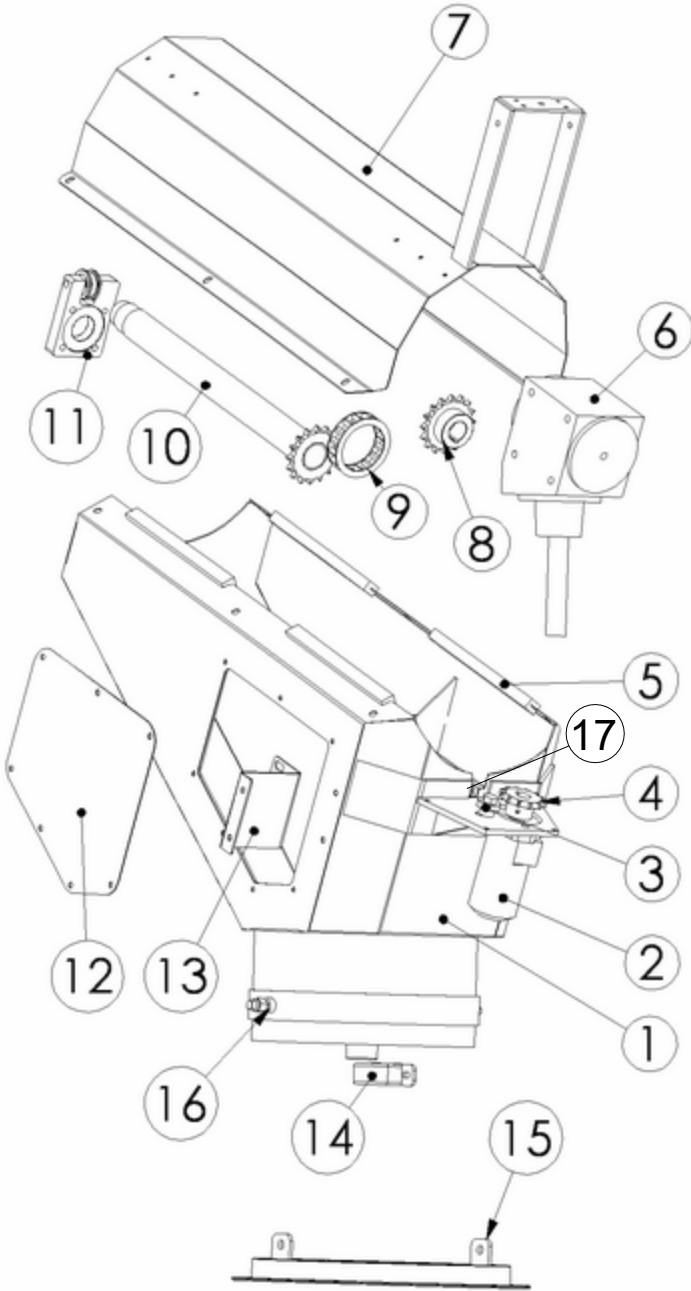

Item	Qty	Part #	Description
0	1	C13-A0	Complete Collector Assembly
1	1	C13-A1	Welded Collector Body
2	1	101-1032	Pinion Brake Motor
	2	H5CZ12.134	Bolt 1/2" NC x 2 1/2"
	2	LWZ12	Lock Washer 1/2"
	2	NHCZ12	Nut 1/2" NC
3	1	6203-5/8-2RS	Pinion Roller Bearing
	1	B3-0.625ID	Pinion Roller Spacer
	1	H5CZ58.212	Bolt 5/8" x 2" NC
	1	FWSAEZC58	Washer 5/8" SAE
	1	LNC58	Lock Nut 5/8"
4	1	WH16-SP6012W	Pinion Sprocket
5	4	W1X0.75X0.5T	Wear Strip
6	1	XGB13	Gearbox 13
	1 L	80W90 Gear Oil	Gear Oil 80w90
	4	H5CZ12.114	Bolts 1/2" NC x 1 1/4
	4	FWZC12	Flat Washer 1/2"
	4	LWZ12	LockWasher 1/2"
7	1	C13-A6	Collector Cover
	4	W3	Collector Cover Wear Strip
	12	SFC14.34	Socket Head Cap Screw Flat
	12	LNC14	Nylon Lock Nut
	6	H5CZ516.114	Bolt 5/16" NC x 1 1/4"
	6	FWZC516	Flat Washer 5/16"
	6	NHCZ516	Nut 5/16" NC
8	1	H22-SP6016XSPC	Hub with Stop
	1	K516-1	Key 5/16" x 1"
9	1	CHA 60-2R-11.25	Double Chain
	1	CHA 60-2R-CO	Connecting Link
10	1	CC-A12-13	Spline Tube Assembly 13
11	1	CRF-A1	Flange With Roller
		(1) CRF-1	Aluminum Roller Flange
		(1) CC-10	Track Roller
		(2) 1621-2RS	Track Roller Bearing
		(1) 6209-2RS	Spline Tube Bearing
		(3) FWSAEZC12	Flatwasher 1/2" SAE
		(1) H5CZ12.5	Bolt 1/2" NC x 5"
		(1) LNC12	Nylon Lock Nut 1/2"
	2	C-2	Collector Stop
	2	SCC38.214	Socket Cap 3/8" x 2 1/4"
	2	LNC38	Nylon Lock Nut 3/8"
	2	H5CZ38.134	Bolt 3/8" NC x 1 3/4"
	2	LWZ38	Lockwasher 3/8"
	2	NHCZ38	Nut 3/8" NC
12	1	C13-28	Door
	5	NWCZ516	Wing Nut
13	1	C13-38	Gearbox Z Bracket
	2	H5CZ12.114	Bolts 1/2" NC x 1 1/4
	2	FWZC12	Flat Washer 1/2"
	2	LWZ12	LockWasher 1/2"
	2	H5CZ38.1	Bolt 3/8" NC x 1"
	2	LWZ38	Lockwasher 3/8"
	2	NHCZ38	Nut 3/8" NC
14	1	PBW-22	Gearbox Lower Steady
	2	H5CZ38.114	3/8" NC x 1 1/4" Bolt
	2	FWSAEZC38	Flat Washer 3/8" SAE
	As Req'	FWZC38	Spacer Washers USS 3/8"
	2	LWZ38	LockWasher 3/8"
	2	NHCZ38	Nut 3/8" NC

15, 16	* See swing ring page	
17	1	CC-10 Track Roller
	2	1621-2RS Track Roller Bearing
	2	FWSAEZC12 Flat Washer 1/2" SAE
	1	H5CZ12.212 Bolt 1/2" NC x 2 1/2"
	1	LNC12 Nylon Lock Nut 1/2"
18	1	HC-3 Hose Clamp 4p
	1	H5CZ38.112 Bolt 3/8" NC x 1 1/2"
	1	LNC38 Lock Nut 3/8"
19	1	HC-1 Hose Clamp 2p
	1	H5CZ38.112 Bolt 3/8" NC x 1 1/4"
	1	LNC38 Lock Nut 3/8"
* See Swing Ring sheet for Part#		

## UC1314-A100 Collector Assembly

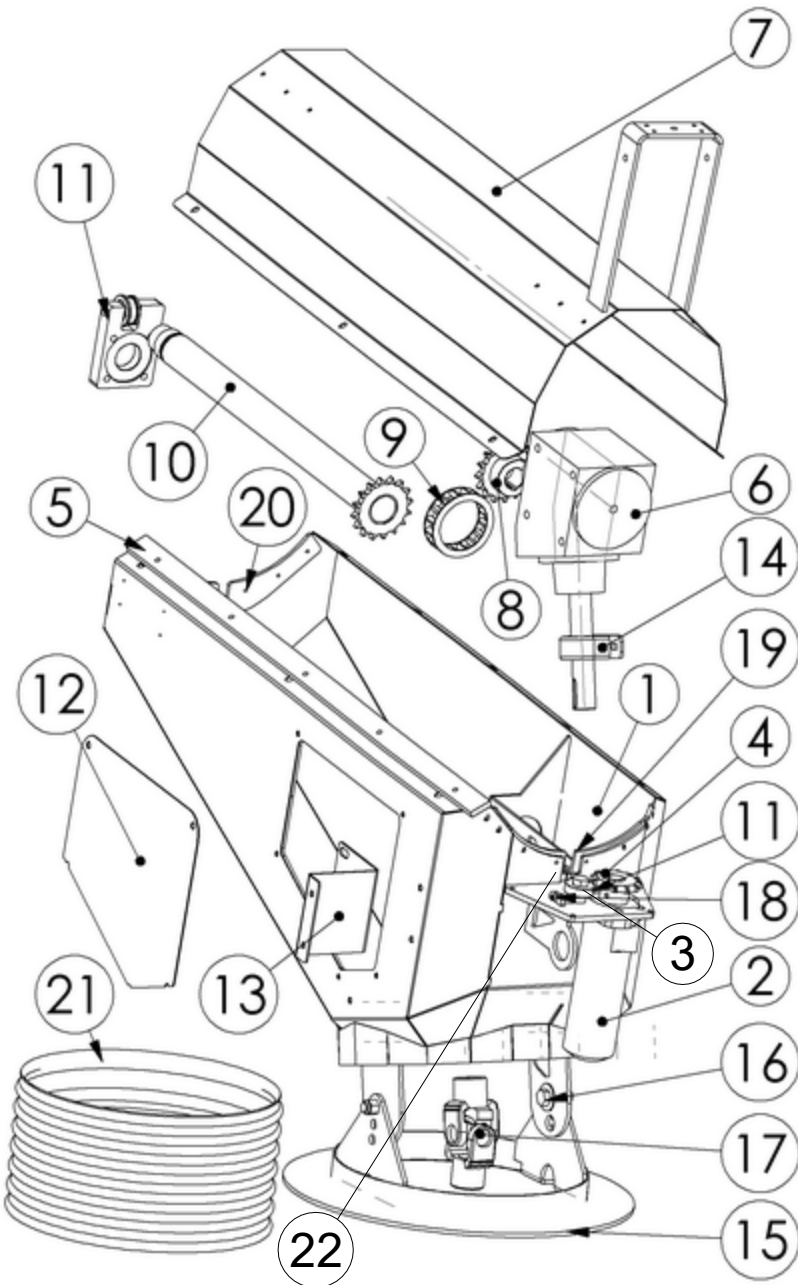

15, 16		* See Swing Ring Page	
	1	DH16-BR13HP	16" Duct Hose Brandt 13 HP
	1	DH16-FK13	16" Duct Hose Farm King 13
	1	DH16-MKX13	16" Duct Hose MKX13
	2	DH16-GC	16" Dia SS Gear Clamp
	22	CC-A10	Track Roller Assembly
Not	2	1621-2RS	Track Roller Bearing
Visible	2	FWSAEZC12	Flat Washer 1/2" SAE
	1	H5CZ12.212	Bolt 1/2" NC x 2 1/2"
	1	LNC12	Nylon Lock Nut 1/2"

Item	Qty	Part #	Description
0	1	UC13-14-A100	Complete Collector Assembly
1	1	UC13-14-A101	Welded Collector Body
2	1	ZBMR-200P4AIYS	Pinion Brake Motor
	2	SCC12.134	Bolt 1/2" NC x 2 1/2"
	2	LWZ12	Lock Washer 1/2"
	2	NHCZ12	Nut 1/2" NC
3	1	6303-2RS	Pinion Roller Bearing
	1	B3-0.625ID	Pinion Roller Spacer
	1	H5CZ58.2	Bolt 5/8" x 2" NC
	1	FWSAEZC58	Washer 5/8" SAE
	1	LNC58	Lock Nut 5/8"
4	1	WH16-SP6012W	Pinion Sprocket
5	2	UC14-663	Wear Strip
6	1	XGB13	Gearbox 13
	1L	80W90 Gear Oil	Gear Oil 80w90
	4	H5CZ12.114	Bolts 1/2" NC x 1 1/4
	4	FWZC12	Flat Washer 1/2"
	4	LWZ12	LockWasher 1/2"
7	1	UC13-A606	Collector Cover
	4	W3	Collector Cover Wear Strip
	12	SFC14.34	Socket Head Cap Screw Flat
	12	LNC14	Nylon Lock Nut
	6	H5CZ516.114	Bolt 5/16" NC x 1 1/4"
	6	FWZC516	Flat Washer 5/16"
	6	NHCZ516	Nut 5/16" NC
8	1	H22-SP6016XSPC	Hub with Stop
	1	K516-1	Key 5/16" x 1"
9	1	CHA 60-2R-11.25	Double Chain
	1	CHA 60-2R-CO	Connecting Link
10	1	CC-A12-DH13-14	Spline Tube Assembly 13/14
11	1	CRF-A1	Flange With Roller
		(1) CRF-1	Aluminum Roller Flange
		(1) CC-10	Track Roller
		(2) 1621-2RS	Track Roller Bearing
		(1) 6209-2RS	Spline Tube Bearing
		(3) FWSAEZC12	Flatwasher 1/2" SAE
		(1) H5CZ12.5	Bolt 1/2" NC x 5"
		(1) LNC12	Nylon Lock Nut 1/2"
	2	C-2	Collector Stop
	2	SCC38.214	Socket Cap 3/8" x2 1/4"
	2	LNC38	Nylon Lock Nut 3/8"
	2	H5CZ38.134	Bolt 3/8" NC x 1 3/4"
	2	LWZ38	Lockwasher 3/8"
	2	NHCZ38	Nut 3/8" NC
12	1	C13-28	Door
	5	NWCZ516	Wing Nut
13	1	C13-38	Gearbox Z Bracket
	2	H5CZ12.114	Bolts 1/2" NC x 1 1/4
	2	FWZC12	Flat Washer 1/2"
	2	LWZ12	LockWasher 1/2"
	2	H5CZ38.1	Bolt 3/8" NC x 1"
	2	LWZ38	Lockwasher 3/8"
	2	NHCZ38	Nut 3/8" NC
14	1	PBW-22	Gearbox Lower Steady
	2	H5CZ38.114	3/8" NC x1 1/4" Bolt
	2	LWZ38	LockWasher 3/8"
	2	NHCZ38	Nut 3/8" NC
17	1	U-Joint	See Table
18	1	SHCS14-212	Jack Screw
	1	LNC14	Nylon Lock Nut
20	2	UC1314-59	CB Side Seal
19	2	C34-57LH	Pinion Side Seal LH
19	2	C34-57RH	10-32 x1" Machine Screw
	14	MPPS1024.58	10-32 SS Nylon Lock Nut
	14	LN18.81024	10-32 SS Nylon Lock Nut

## UC1314-A300 Collector Assembly

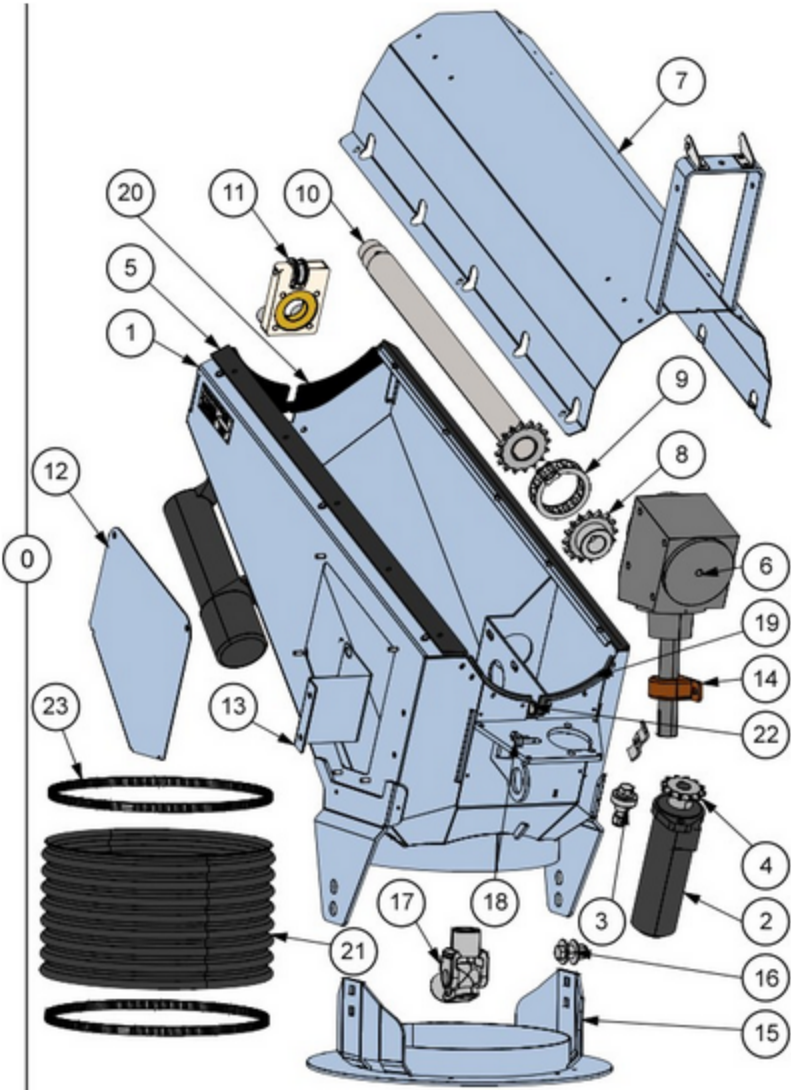

Item	Qty	Part #	Description
0	1	UC13-14-A300	Complete Collector Assembly
1	1	UC13-14-A301	Welded Collector Body
2	1	ZBMR-200P4AIYS	Pinion Brake Motor
	1	ZBMR-SK-UNIV	Brake Motor Seal Kit
	2	SCC12.134	Bolt 1/2" NC x 1 3/4"
	2	LWZ12	LockWasher 1/2"
	2	NHCZ12	Nut 1/2" NC
3	1	6303-2RS	Pinion Roller Bearing
	1	B3-0.625ID	Pinion Roller Spacer
	1	H5CZ58.2	Bolt 5/8" x 2" NC
	1	FWSAEZC58	Washer 5/8" SAE
	1	LNC58	LockNut 5/8"
4	1	WH16-SP6012W	Pinion Sprocket
5	2	UC14-663	Wear Strip
6	1	XGB13	Gearbox 13
	1L	80W90 Gear Oil	Gear Oil 80w90
	4	H5CZ12.114	Bolts 1/2" NC x 1 1/4"
	4	FWZC12	Flat Washer 1/2"
	4	LWZ12	LockWasher 1/2"
7	1	UC13-A606	Collector Cover
	4	W3	Collector Cover Wear Strip
	12	SFC14.34	Socket Head Cap Screw Flat
	12	LNC14	Nylon Lock Nut
	6	H5CZ516.114	Bolt 5/16" NC x 1 1/4"
	6	FWZC516	Flat Washer 5/16"
	6	NHCZ516	Nut 5/16" NC
8	1	H22-SP6016XSPC	Hub with Stop
	1	K516-1	Key 5/16" x 1"
9	1	CHA 60-2R-11.25	Double Chain
	1	CHA 60-2R-CO	Connecting Link
10	1	CC-A12-DH13-14	Spline Tube Assembly 13/14
11	1	CRF-A1	Flange With Roller
		(1) CRF-1	Aluminum Roller Flange
		(1) CC-10	Track Roller
		(2) 1621-2RS	Track Roller Bearing
		(1) 6209-2RS	Spline Tube Bearing
		(3) FW SAEZC12	Flatwasher 1/2" SAE
		(1) H5CZ12.5	Bolt 1/2" NC x 5"
		(1) LNC12	Nylon Lock Nut 1/2"
	2	C-2	Collector Stop
	2	SCC38.214	Socket Cap 3/8" x2 1/4"
	2	LNC38	Nylon Lock Nut 3/8"
	2	H5CZ38.134	Bolt 3/8" NC x 1 3/4"
	2	LWZ38	Lockwasher 3/8"
	2	NHCZ38	Nut 3/8" NC
12	1	C13-28	Door
	5	NWCZ516	Wing Nut
13	1	C13-38	Gearbox Z Bracket
	2	H5CZ12.114	Bolts 1/2" NC x 1 1/4"
	2	FWZC12	Flat Washer 1/2"
	2	LWZ12	LockWasher 1/2"
	2	H5CZ38.1	Bolt 3/8" NC x 1"
	2	LWZ38	Lockwasher 3/8"
	2	NHCZ38	Nut 3/8" NC
14	1	PBW-22	Gearbox Lower Steady
	2	H5CZ38.114	3/8" NC x1 1/4" Bolt
	2	LWZ38	LockWasher 3/8"
	2	NHCZ38	Nut 3/8" NC
17	1	U-Joint	See Table
18	1	SHCS14-212	Jack Screw
	1	LNC14	Nylon Lock Nut
20	2	UC1314-59	CB Side Seal

19	2	C34-57LH	Pinion Side Seal LH
19	2	C34-57RH	Pinion Side Seal RH
14		MPPS1024.58	10-32 SS Nylon Lock Nut
14		LN18.81024	10-32 SS Nylon Lock Nut
15, 16		* See Swing Ring Page	
21	1	DH16-BR13HP	16" Hose Brandt 13 HP (15R)
	1	DH16-FK13	16" Hose Farm King 13 (13R)
	1	DH16-MKX13	16" Duct Hose MKX13 (12R)
23	2	DH16-GC	16" Dia SS Gear Clamp
22	1	CC-A10	Track Roller Assembly
Not Visible	2	1621-2RS	Track Roller Bearing
	2	FW SAEZC12	Flat Washer 1/2" SAE
	1	H5CZ12.212	Bolt 1/2" NC x 2 1/2"
	1	LNC12	Nylon Lock Nut 1/2"

## CB13-A0 Chainbox Assembly

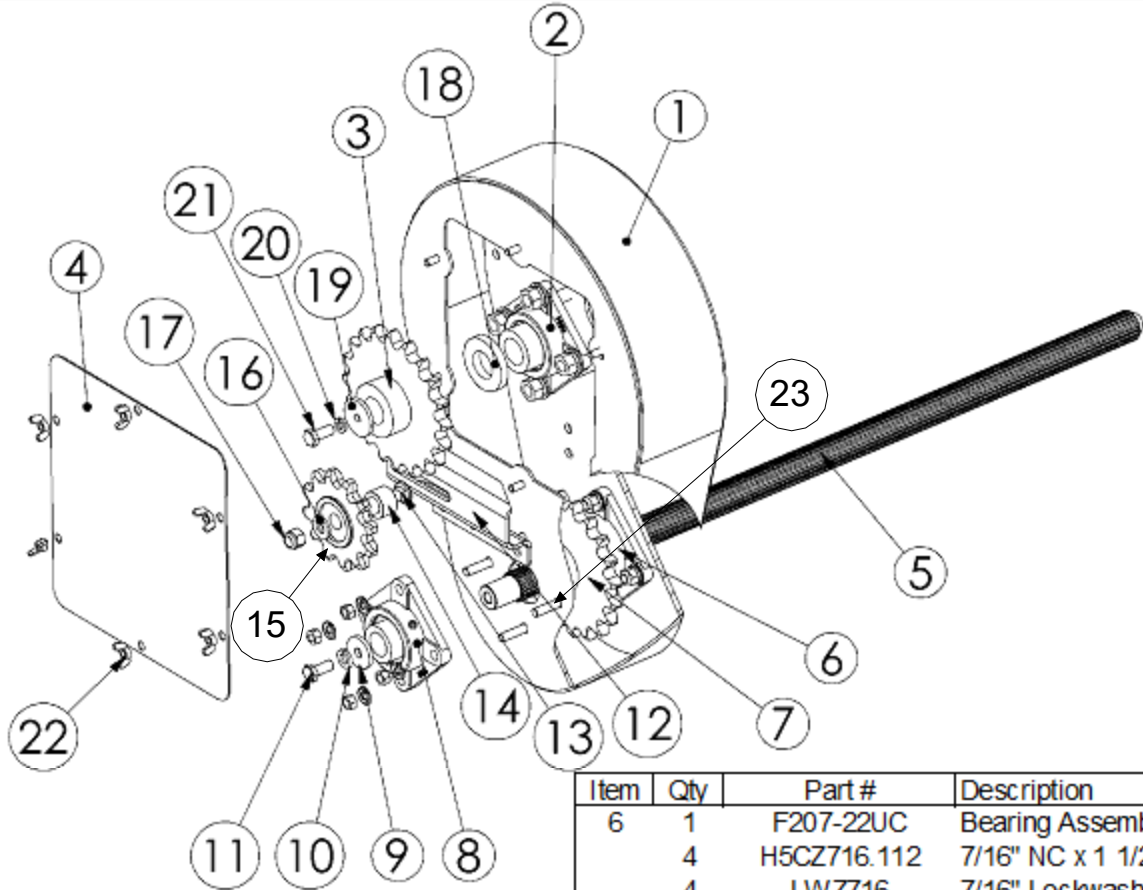

Item	Qty	Part #	Description
0	1	CB13-A0	Complete Chain Box Assem
1	1	CB13-A1	Welded Chainbox
4	4	H5CZ716.114	7/16" NC x 1 1/4" Bolt
3	4	H5CZ716.112	7/16" NC x 1 1/2" Bolt
7	4	LWZ716	7/16" Loc kwasher
7	4	NHCZ716	7/16" NC Nut
2	1	F206-20G	Bearing Assem w/Lock Collar
4	4	H5CZ716.112	7/16" NC x 1 1/2" Bolt
4	4	LWZ716	7/16" Loc kwasher
4	4	NHCZ716	7/16" NC Nut
3	1	WH20-SP8020X	Hub with 8020X (Standard)
or	1	WH20-SP8024X	Hub & 8024X (Meridian 12")
*	1	K25-125	1/4" x 1 1/4" Key
4	1	CB13-44	Chain Box Door
22	6	NWCZ516	5/16" Wing Nut
5	1	CB-35-13	Upper Spline Shaft (30 3/4")
or	1	CB-35-16	Spline Shaft (36") 2016+ DH
*	1	CHA 80-43	Drive Chain 43" (8020)
*	1	CHA 80-45	Drive Chain 45" (8024)
*	1	CHA 80-1R-CO	Connecting Link
*	Not Shown		

Item	Qty	Part #	Description
6	1	F207-22UC	Bearing Assembly
4	4	H5CZ716.112	7/16" NC x 1 1/2" Bolt
4	4	LWZ716	7/16" Lockwasher
1	1	FWSAEZC716	7/16" SAE Flatwasher
4	4	NHCZ716	7/16" NC Nut
7	1	WSH-SP8020X	Spline Hub w/ 8020 Sprocket
8	1	F206-18G	Bearing Assem w/Lock Collar
4	4	H5CZ38.114	3/8" NC x 1 1/4" Bolts
4	4	LWZ38	Lock Washers
4	4	NHCZ38	3/8" NC Nut
9	1	FW.52X1.75X0.2	Heavy Washer
10	1	LWZ12	Lockwasher 1/2" GR8
11	1	H8FZ12.1	1/2" Fine x 1" Bolt
12	1	CBC-1	Tightener Z Brac ket
13	1	CBZ12.212	1/2" x 2.5" Carriage Bolt
14	1	CB14-20	Tightener Spacer (2016+)
1	1	CBC-2	Chain Tightener Spacer
15	1	ID80A12-3/4	Idler Sprocket (2016+)
1	1	CTA-80-12	Chain Tensioner w bearings
16	1	FWSAEZC12	SAE Flatwasher 1/2"
17	1	LNC12	Nylon Lock Nut 1/2"
18	1	CBC-5	Drive Spac er 1.3 x 2.5 x 0.375
19	1	FW.4x1.5x.2	Heavy Washer
20	1	LWZ38	Lockwasher 3/8"
21	1	H5CZ38.1	3/8" NC x 1" Bolt
23	1	CBC-A76	Retainer Assembly with bolts

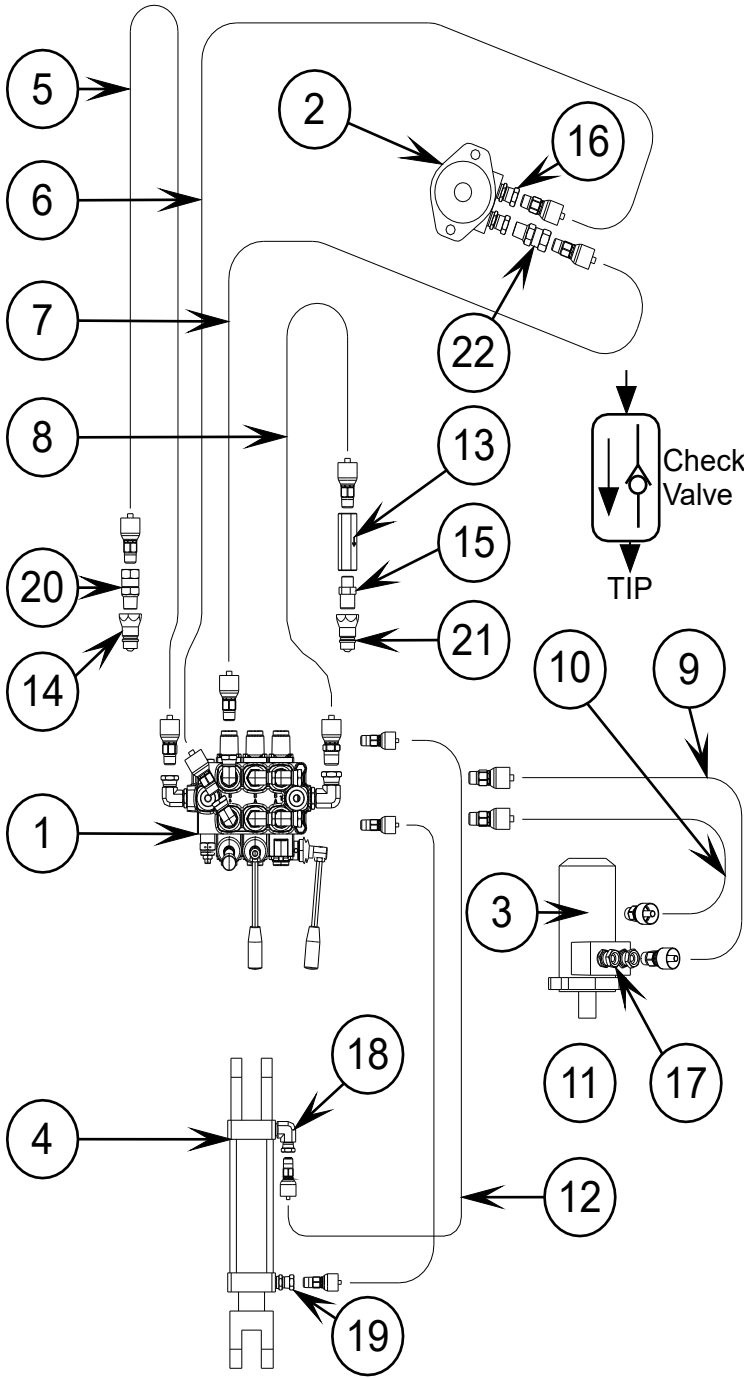

Item	Qty	Part #	Description	Connection
1	1	RC-A2	Valve Assembly (with fittings)	
2	1	ZBMR-200P4AIY5	Pinion Motor (Brake Motor)	
3	1	BMPH-400P4A11Y9	Wheel Drive Motor	
4	1	25TL04-112	Tilt Cylinder (with pins)	
5	1	HYD-5	Hose Assembly	
	29'	WPH6-2	3/8" 2 wire hose	
	1	10143-8X6	1/2" NPT Hose End	Coupler
	1	10143-6X6	3/8" NPT Hose End	Valve
6	1	HYD-6	Hose Assembly	
	200"	WPH6-2	3/8" 2 wire hose	
	1	10143-6X6	3/8" NPT Hose End	Valve
	1	10143-6X6	3/8" NPT Hose End	Motor
7	1	HYD-6	Hose Assembly	
	200"	WPH6-2	3/8" 2 wire hose	
	1	10143-6X6	3/8" NPT Hose End	Valve
	1	10143-6X6	3/8" NPT Hose End	Motor
8	1	HYD-5	Hose Assembly	
	29'	WPH6-2	3/8" 2 wire hose	
	1	10143-8X6	1/2" NPT Hose End	Valve
	1	10143-6X6	3/8" NPT Hose End	Coupler
	1	10143-6X6	3/8" NPT Hose End	Valve
9	1	HYD13-9	Hose Assembly	Wheel Drive
	50"	WPH6-2	3/8" 2 wire hose	
	1	10143-6X6	3/8" NPT Hose End	Valve
	1	10143-6X6	3/8" NPT Hose End	Motor
10	1	HYD13-9	Hose Assembly	Wheel Drive
	50"	WPH6-2	3/8" 2 wire hose	
	1	10143-6X6	3/8" NPT Hose End	Valve
	1	10143-6X6	3/8" NPT Hose End	Motor
11	1	HYD13-11	Hose Assembly	Cylinder
	72"	WPH4-2	1/4" 2 wire hose	
	1	10143-4X4	1/4" NPT Hose End	Valve
	1	10143-4X4	1/4" NPT Hose End	Rod-End
12	1	HYD13-12	Hose Assembly	Cylinder
	76"	WPH4-2	1/4" 2 wire hose	
	1	10143-4X4	1/4" NPT Hose End	Valve
	1	10143-4X4	1/4" NPT Hose End	Clevis End
13	1	C-375-S-5	3/8" Check Valve	
14	1	8010-4MB	Pioneer Coupler Male	
15	1	0101-6X8	3/8" MNPT to 1/2" MNPT Adapter	
16	2	0507-10X6	#10 ORB M to 3/8" F Swivel	
17	2	0107-8X6	1/2" M to 3/8" F Swivel	
18	1	2107-6X4	3/8" M to 1/4" F Swivel 90	
19	1	0107-6X4	3/8" M to 1/4" F Swivel	
20	1	9205-08-08R.062	Orifice Fitting	
21	1	MANQAPN0808NPTF	Connect Under Pressure Coupler	
22	1	1404-06-06R.062	Orifice Fitting	

Seal Kits are Available ie (ZBMR-SK-UNIV, 25TL-SK, and BMPH-SK)

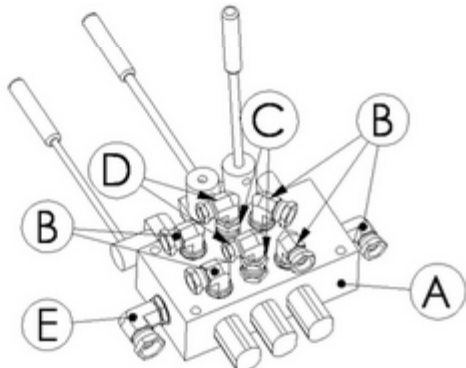

		RC-A2	Valve Assembly (with fittings)
Item	Qty	Part #	Description
A	1	VLV-3SP-WHDL	Valve with Handles
B	5	2507-8X6	#8 ORB to 3/8" FNPT 90 Swivel
C	2	0507-8X6	#8 ORB to 3/8" FNPT Swivel
D	2	2107-6X4	3/8" M to 1/4" F Swivel 90
E	1	2507-10X8	#10 ORB to 1/2" FNPT 90 Swivel

The Xtend swing auger is connected by the swing auger through the Swing Ring or Pivot Flange. It is imperative that the height of the pivot above the auger deck be the same as for the swing that was removed. The ring dimensions are given here so that they can be checked against the factory swing before installation. The size and type and bore of the U-Joint has also changed over the years and between manufactures. This must also be checked.

### Steel Ring Type

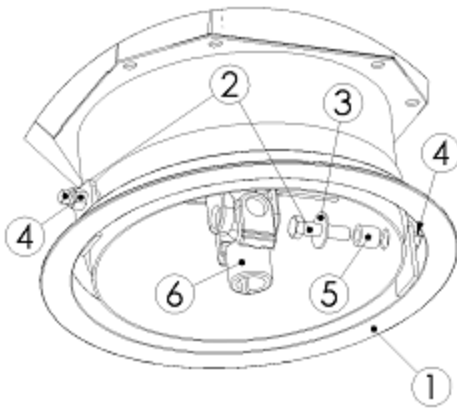

### Dust Hose Type 2016-2024

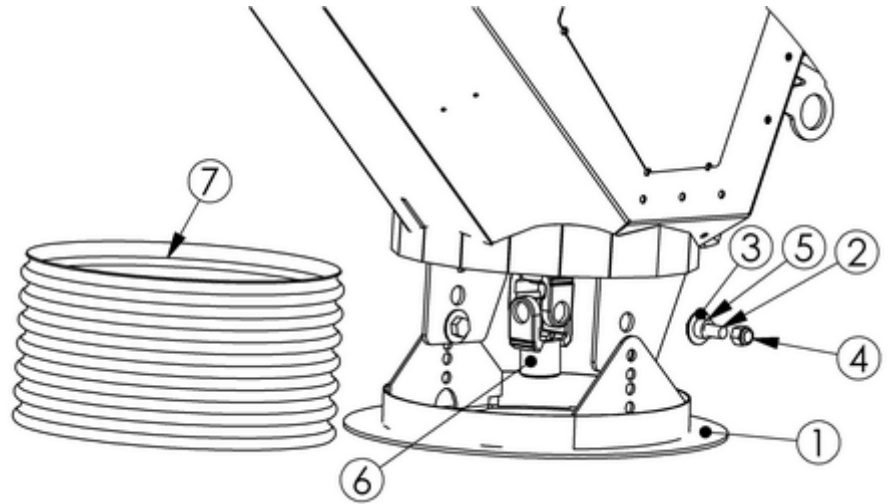

Item	Qty	Part #	Description
1	1	SSR-*	Swing Ring (Model Dependant)
2	2	Bolt	5/8" Gr 5 NC Bolt
3	2	FWZC58	Flat Washer 5/8"
4	2	LNC58	Nylon Lock Nut 5/8" NC
5	2	SRB-*	Swing Bushing (Model Dependant)
6	1	U-Joint	Usually Use Factory U-Joint**

Item	Qty	Part #	Description
1	1	SR13-*	Swing Ring (Model Dependant)
2	2	Carriage Bolt	5/8" Gr 5 NC Carriage Bolt
3	4	FWZC58	Flat Washer 5/8"
4	2	LNC58	Nylon Lock Nut 5/8" NC
5	2	B3-0.625ID	Swing Bushing
6	1	U-Joint	Usually Use Factory U-Joint**
7	1	DH16.BR13HP	16" Dust Hose Brandt 13HP (15R)
	1	DH16-FK13	16" Dust Hose Farm King 13 (13R)
	1	DH16-MKX13	16" Dust Hose Brandt AGI13 (12R)
	1	DH16-MER12	16" Dust Hose Meridian 12 (12R)

U-Joints		
Manufacturer	Supplier	Part #
Farm King 13	Buhler	#960784
Brandt	Factory	U-joint from Auger
Westfield/ Wheatheart	Rodono	UA1222-14SPL
	Westfield	10-22868

U-Joints or CV Joints		
Manufacturer	Supplier	Part #
Farm King 13 (CV)	Buhler	917913
Farm King Double	Buhler	930508
Brandt	Factory	U-joint from Auger
Westfield/ Wheatheart	Rodono	UA1222-14SPL

930508 is interchangeable with 917913  
930508 is current as of 2021

XTEND SWING RING TYPES							Dust Hose		
Augers Used On	Swing Ring DH Type Only	SH	ROD	Joint Type	Driveline #	Length	Rings		
Farm King 19?? To 2013	SR13DH-FK-2013	3" or 3 3/4"	20"	U-Joint	Buhler	1.3'	13		
Farm King 2014+	SR13DH-FK-2014	4 3/4"	19"	CV Joint	Buhler	1.3'	13		
Brandt XL To 2016	SR13DH-XL-Brandt-2016	4 3/8"	19 1/8"	U-Joint	Brandt	1.1'	11		
Brandt HP & XL 2017+	SR14DH-HPXL-Brandt-2017	5 7/8"	22"	U-Joint	Brandt	1.5'	15		
Older Brandt 19?? To 20??	N/A	2 3/16"	19 1/8"	U-Joint	Brandt	N/A	N/A		
Meridian 12"									12
Meridian 13"					Driveline UA-14-Mer13				14
WestField MK Plus	SR13DH-MKPlus	1 1/2"	19 1/4"	U-Joint	*UA1222-14SPL	1.3'	13		
Wheatheart X / Westfield MKX	SR13DH-MKX-WH/WF	4 3/4"	20"	U-Joint	*UA1222-14SPL	1.3'	13		

\* Supplied by Rodono

## WD16U-A0 Wheel Drive Assembly

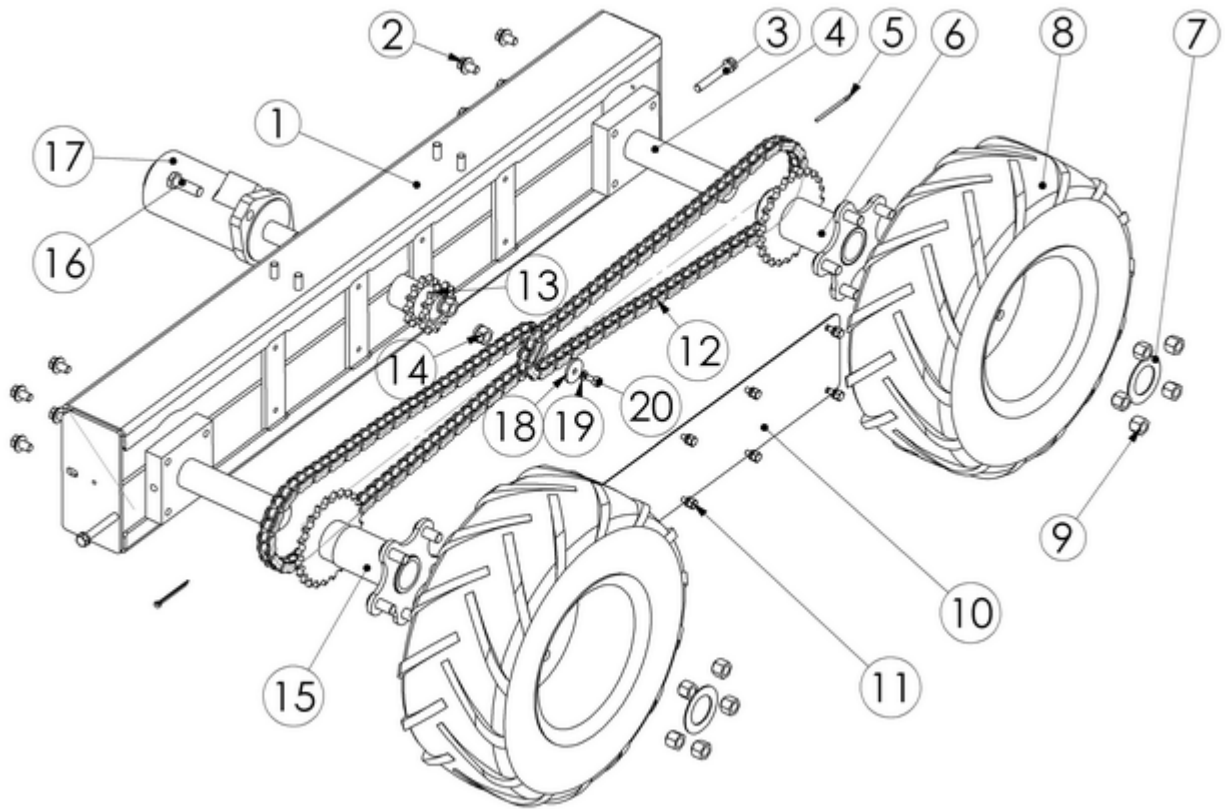

0	1	WD16U-A0	Wheel Drive Assembly
1	1	WD16U-A1	Welded Wheel Drive Frame
2	8	H8CZ38.034	Bolt 3/8" NC Gr 8 x 3/4"
	8	LW838	Lockwasher 3/8" Gr 8
	8	FW838	Flat Washer 3/8" Gr 8
3	2	H5CZ38.212	Bolt 3/8" NC Gr5 x 2 1/2"
	2	LWZ38	Lockwasher 3/8"
4	2	WD16-A5	Spindle
5	2	CP316.2	Cotter Pin
6	1	WD16-A3	Outer Rotating Hub
7	2	W150-200	Machine Washer
8	2	TSL16	Super Lug 16" Wheel & Tire
9	10	WB11	Wheel Nut
10	1	WD16U-14	Front Stiffener

11	8	LWZ14	Lock Washers - 1/4"
	8	H5CZ14.012	Bolt 1/4"NC x 1/2"
12	2	CHA 50-46	50 Roller Chain
	2	CHA 50-1R-CO	50 Connecting Link
13	1	WD16-A4	Drive Double Sprocket
14	2	NHCZ12	Nut 1/2" NC
	2	LWZ12	Lock Washers - 1/2"
15	1	WD16-A2	Inner Rotating Hub
16	2	H5CZ12.112	Bolt 1/2" NC x 1 1/2"
17	1	BMPH-400P4A11Y9	Wheel Drive Motor
	*	101-1032-009	Used for early models
18	1	WD16U-9	Machine Washer
19	2	LWZ14	Lock Washers - 1/4"
20	1	H5CZ14.034	Bolt 1/4" NC x 3/4"

Notes: Distance between Sprocket and Flange is 3.5" for the outer hub (6) and 4.5" for the inner hub (15)

## Maintenance

Greasing Schedule					
Description	Qty	Location	Frequency	Diagram	Item
U-Joints	1	Lower Hopper	80 hrs Operation	Hopper	5
	1	Upper Hopper	80 hrs Operation	Hopper	5
	1	Collector	80 hrs Operation	Swing Ring	6
Bushings	2	Hopper Feed Screw	8 hrs Operation	Hopper	5
	1	Hopper Jack Shaft	8 hrs Operation	Hopper	7
	1	Transition Screw	8 hrs Operation	Hopper	9
Bearings	2	Hopper Feed Screw	200 hrs Operation	Hopper	14
	1	Jack Shaft	200 hrs Operation	Hopper	15
	3	Chain Box Bearings	200 hrs Operation	Chain Box	2,6,8

Oil Schedule	
Chain Box	Greased at Factory -Add Grease through zerk - 80 hrs
Gearbox	Fill to Level SAE 90 Initially- Check and Maintain Level Yearly
Spline Shaft	Apply Light Oil- Monitor and Keep Clean and Lightly Oiled Apply Grease for Storage
Hopper Drive Chain	Apply oil when greasing - 80 hrs

Greasing	U-Joints	1 Pump	High Temp
Gearbox Oil	SAE 90		

### Contacts:

Rodono Industries Ltd.  
RR#1  
Clive, Alberta  
T0C 0Y0  
Phone 403-784-3864  
Fax 403-784-2402

email: [contact@rodono.ca](mailto:contact@rodono.ca)  
website: [www.rodono.ca](http://www.rodono.ca)

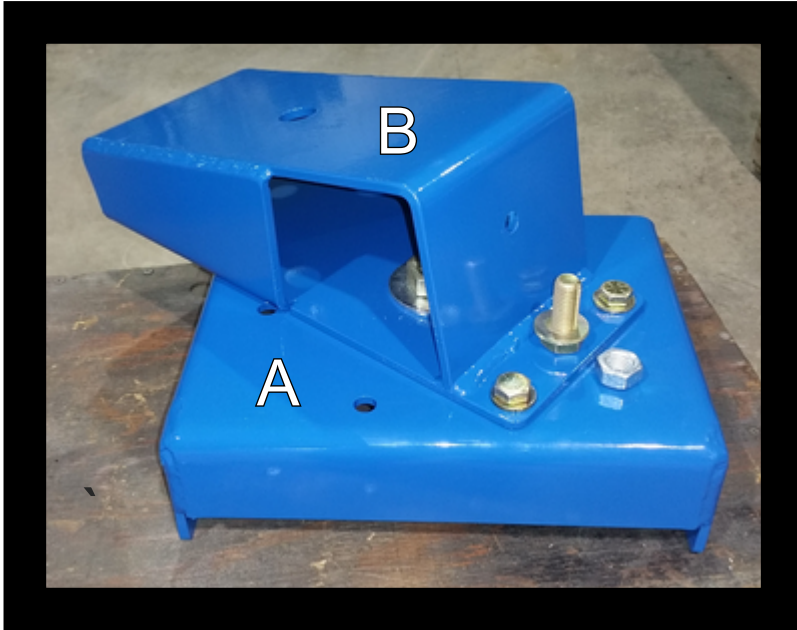

The winch mount to fit an Xtend on a Brandt HP for 2017 is meant to bolt on. It will require drilling 6 holes at 1/2" and enlarging the pin hole to 5/8"

This Bracket assembly inserts between the current winch arm and the current winch mount to swing the hook further back and tilt the arm down to allow use of the factory winch arm without cutting and welding like previous models.

It will still swivel from side to side on some lengths of Brandt Augers if there is enough clearance to the cable mount frame.

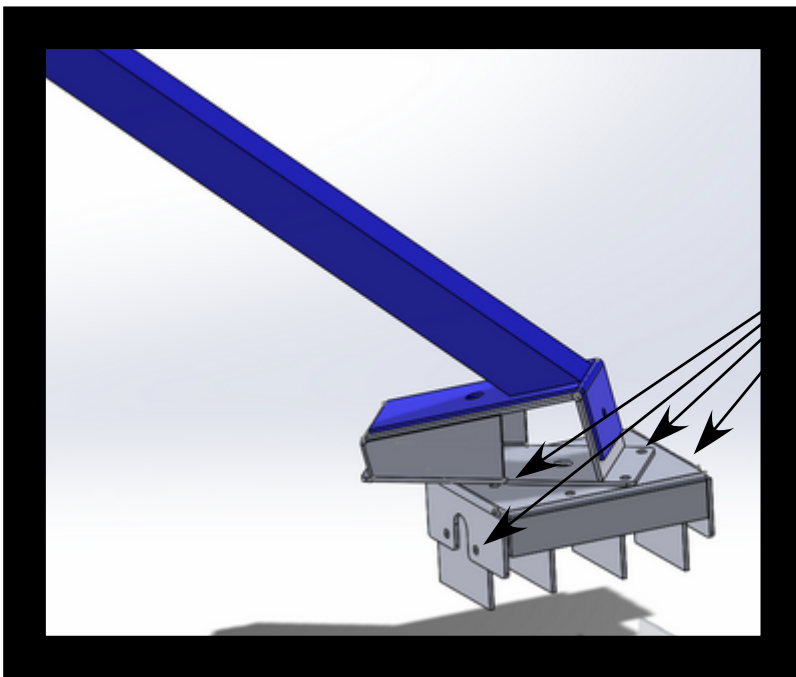

- 1: Remove Brandt Winch arm from its mount
- 2: Place lower piece of winch kit in place on Brandt winch mount. Use 1" bolt to hold the mount in place temporarily.

- 3: Drill through Brandt winch mount in 6 places with 1/2" drill bit.  
2 on top  
4 on side.

- 4: Remove the 1" Bolt. Place the top part of mount in place. Install and tighten 4 of 1/2" NC x 1 1/4" Bolts in sides  
2 of 1/2" NC x 1 1/2" Bolts in top and the 1"NC x 2" Bolt in the middle.

- 5: Bolt the Brandt winch arm back in place on top of the new mount. Drill the small pin hole out to 5/8" and install the 5/8" bolt with the stover lock nut.

- 6: Test for safe operation and clearances.

### Kit Includes

A: Lower Mount

B: Upper Mount

4- Gr 8- 1/2" NC x 1 1/4" Bolts

2- Gr 8- 1/2" NC x 1 1/2" Bolts

6- Gr 8- SAE Flat Washers

6- Gr 8- Lockwashers

6- Gr 8- 1/2" NC Nuts

1- Gr 8- 1" NC x 2" Bolt

1- Gr 8- 1" Lockwasher

1- 1" Flat Washer

1- Gr 8- 1"NC Nut

1- Gr 8- 5/8" NC x 1 1/2 Bolt

1- Gr 8- SAE Flat Washer

1- 5/8" NC Stover

Square tube is supplied to extend the Brandt winch arm if the swing hits the auger frame. This should only be required on 2017 Brandt Augers.



Farm King winch Mounts bolt onto the support bracket for the main auger a-Frame 4 holes are required to be drilled. Bolts and Bars are supplied. Move the winch arm to the new mount. Shown on 1385. The mount always goes in the position shown, but is harder to drill when the auger A-Frame is on the rear pivot position.

Farm King 13x70 is a Weld on Mount. We recommend the longer augers when using Super-B Trailers.

Wheatheart and Westfield Mounts vary for each Length of auger. Please contact us for the Winch Mount configuration Sheet.