

Rodono does some custom manufacturing for FarmKing, Westfield, Wheatheart, Grainmaxx and Meridian. If there is a Rodono Serial number plate on the side of the collector, then this manual applies.

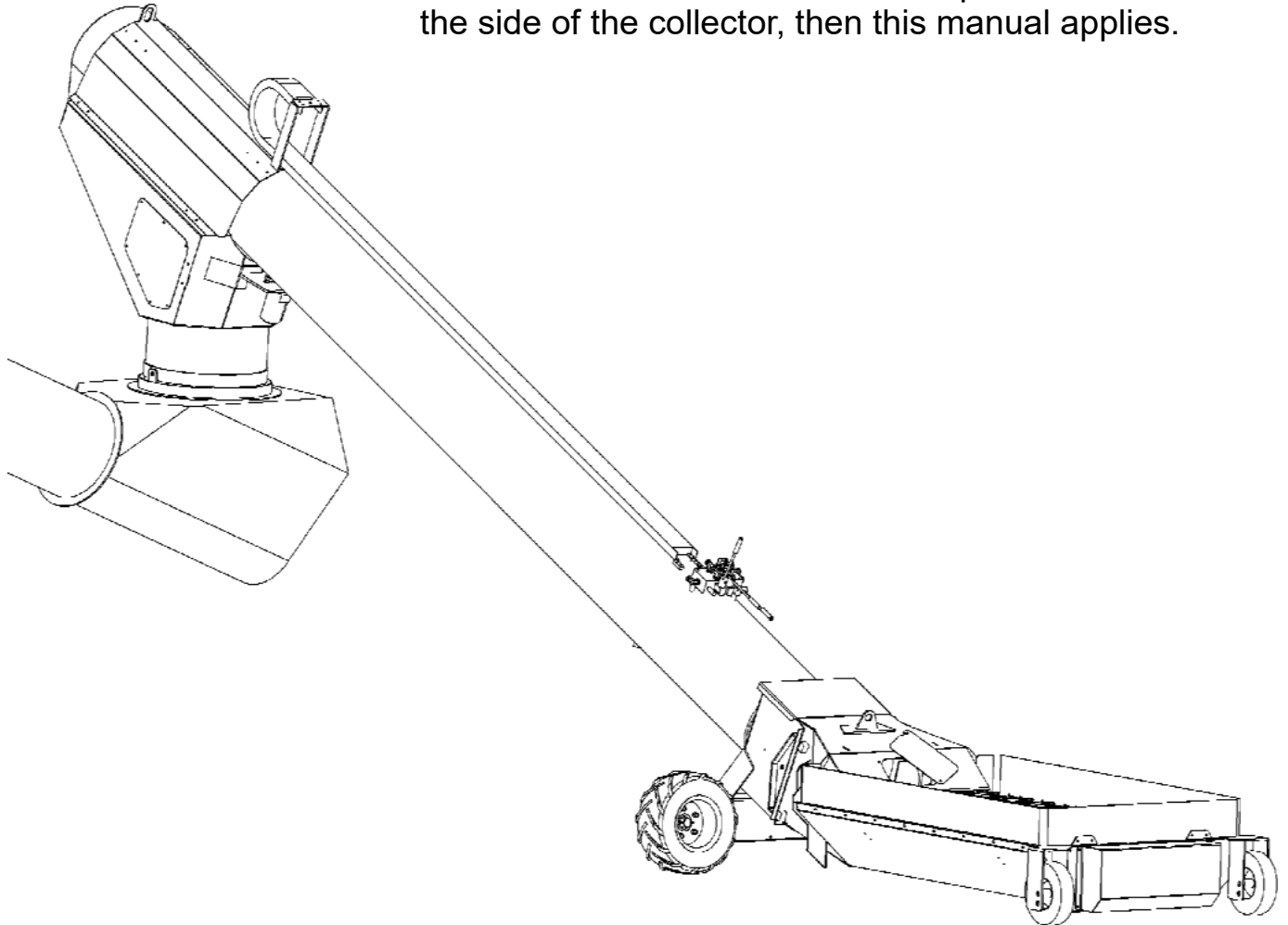

Revisions:
3 Screw Hopper Introduced Mid 2014
Geared to Match Auger
Farm King 16
Wheatheart 16
Brandt 16HP

In 2015- Hose Type Collector Introduced
Uses Custom Driveline for Swing to Auger
(Instead of Farm King CV)
Uses XGB16-R4 Gearbox (Short Shaft w Bolt)

Xtend 16" Installation and Parts Manual

May 22/2026

Table of Contents

Introduction	3
Safety	4
Installation	6
Operation	8
Parts Drawings	9
Maintenance	19
Greasing Locations	20

Introduction

The Rodono Xtend swing auger is designed to replace the existing swing auger on many different augers manufactured today and in the past. It provides the freedom to drive hopper bottom trailers into place with the intake hopper retracted. The intake hopper may be extended under the trailer under operator control safely and with ease once the trailer is stopped. The Xtend auger is available in 13", 14" and 16" models. The mounting ring is specific to the type of auger that the Xtend is added to. Please be familiar with the operation and safety instructions of your specific auger before adding an Xtend auger to it. This manual is only relevant to the Xtend auger and does not replace or supercede the auger manufacturers instructions.

The specifications for the different models can be found on our website at www.rodono.ca. This equipment can be added to several different manufacturers augers, many of which have had many changes over the years. We try and cover all the possible configurations, but if your installation does not match the documentation please contact us so that we can ensure your equipment will function properly.

SAFETY

Safety is the protection of YOU and the people around you. Do not take risks with your life or others around you. Be certain that everyone operating this equipment is familiar with the recommended operating and maintenance procedures and follows all the safety precautions. Do not risk injury or death by ignoring good safety practices.

Most accidents can be prevented.

The safety symbols and warnings used throughout this manual and on the equipment are specified by the ASABE in specifications related to all farm equipment and specifically portable grain augers. These warnings are meant to make you aware of risks to you. Please understand what they mean and pay attention.



CAUTION

The caution symbol indicates a potentially hazardous situation that, if not avoided, may result in minor or moderate injury. It may also be used to alert against unsafe practices.



WARNING

The Warning Symbol indicates a potentially hazardous situation that, if not avoided, could result in death or serious injury, and includes hazards that are exposed when guards are removed. It may also be used to alert against unsafe practices.



DANGER

The Danger Symbol indicates an imminently hazardous situation that, if not avoided will result in death or serious injury. This signal word is to be limited to the most extreme situations, typically for machine components that, for functional purposes, cannot be guarded.

If for any reason a warning label is damaged, missing or unreadable it is the responsibility of the operator or machine owner to order new ones which must be available from the manufacturer. This applies to the main equipment as well as additions. Please do not hesitate to contact us for new labels.

Decal and Label Locations

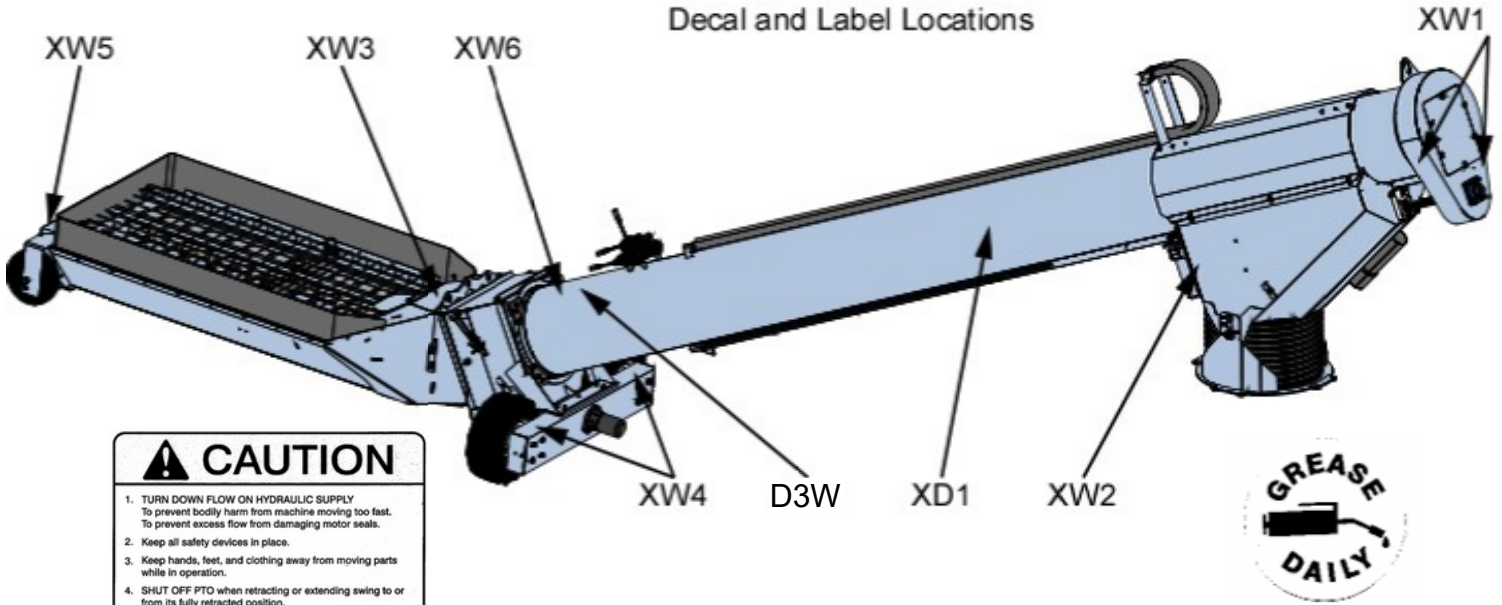

CAUTION

- TURN DOWN FLOW ON HYDRAULIC SUPPLY
To prevent bodily harm from machine moving too fast.
To prevent excess flow from damaging motor seats.
- Keep all safety devices in place.
- Keep hands, feet, and clothing away from moving parts while in operation.
- SHUT OFF PTO when retracting or extending swing to or from its fully retracted position.
- Engaging spline shaft with PTO running will damage the machine.
- Make certain everyone is clear of the equipment before applying power or moving the machine.

XW6 - Caution Decal



XWG - multiple locations

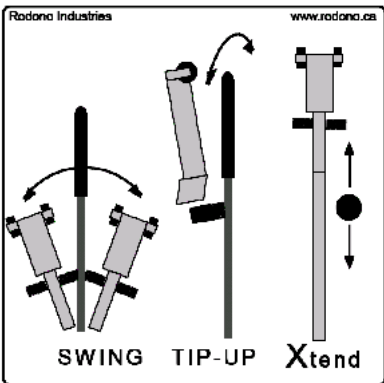

D3W - Hydraulic Control Decal

CAUTION

MOVING EQUIPMENT
This machine moves in all directions under operator control

XW4 - Moving Equipment Warning

DANGER
MISSING SHIELD

XW5 - Danger Missing Shield

WARNING

ROTATING PART HAZARD

To prevent serious injury or death from rotating parts.

- Stop Engine, disengage PTO, wait for all moving parts to stop before servicing, adjusting, repairing or unplugging.
- Install and secure all guards and close and secure access doors before operating.
- Keep children and bystanders away.

XW2 - Rotating Part Warning

WARNING

Moving Parts will cause severe injury.
KEEP AWAY

ROTATING SHAFT
Keep hair and loose clothing away.

XW1 - Rotating Part Warning

DANGER

ROTATING FLIGHTING HAZARD

To prevent serious injury or death from flighting:

- Keep all guards in place and in good condition when operating.
- Do not operate with flighting guard removed or access doors open.
- Keep hands, feet, hair and clothing away from flighting.
- Keep children and bystanders away.

XW3 - Rotating Flighting Warning

Installation:

- 1: Swing your old swing auger into a position out from the side of your auger that is safe to lift.
- 2: Secure an appropriate lifting device with appropriate lifting straps or chains to your old swing.
- 3: Apply slight tension to prevent swing from falling when the fasteners are removed.
- 4: Remove the bolts and washers that hold swivel ring of your old swing unit down to the auger deck. Keep the parts for use on your new Xtend Swing.
- 5: Usually the lower half of the U-Joint that connects the swing auger to main auger is splined and should slip up as the swing auger is lifted. If the spline is seized (usually due to running fertilizer through the auger) then it may have to be pried off, and sometimes heating is necessary. Lift the old swing auger off the main auger deck in a safe manner.
- 6: The center of the U-Joint needs to be aligned with the swivel between the ring and the lower spout of the Xtend swing auger. Check the height from the bottom of the ring you removed to the pivot pin in the ring. This height should match the height on the ring supplied with the Xtend swing. If it does not, please contact Rodono Industries to discuss the issue.
- 7: The U-Joint can be taken off the old swing and put on the new Xtend swing. The center of the u-joint must be placed in line with the swivel. This can be done by measuring the height above the ring with a straight edge across the bottom of the ring. See the proper value for dimension A in the table below. If it does not look correct you can take one of the swing bolts out and look through the hole in the bushing and see if the u-joint bearing is in line with the pivot. If you are sure it is in line you can lock it in place on the upper shaft.
- 8: The Xtend swing can be lowered into place on the main auger using the same lift system that you lifted the old one off. Grease the lower spline before lowering the auger. The u-joint can be aligned through the door on the side of the collector. Lower the Xtend auger into place.
- 9: The bolts and washers can be put back in place to hold the ring down. If they are adjustable, there should be clearance between the ring and the bushing on the bolts so that the ring is free to turn and shift a small amount if necessary.

Operation

The Xtend Swing auger adds two functions to a normal swing auger.

- 1: The ability to extend and retract.
- 2: The ability to tilt the end of the hopper up or down.

This allows the machine to either extend or swing.

The swing auger also has power swing.

All controls for these functions are conveniently located at the end of the swing tube where the operator has easy access to the handles on the trailer for opening the chute gates.

The controls are clearly identified on the label by the controls (Shown Below)

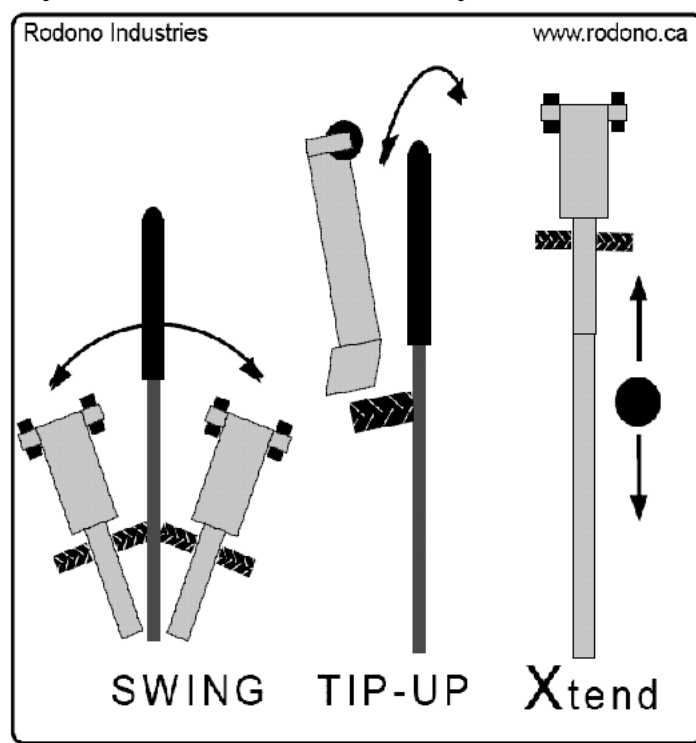

Notes on hydraulics and capacity

The tractor hydraulic flow to this unit should be turned down. This will help prevent damage to the equipment and the operator. The flow should be turned down to the point where the operator is comfortable with the swing speed and the retraction speed while holding onto the controls.

As with all swing augers. It is possible for the swing to overfeed the main auger if the main auger is approaching or exceeding its maximum angle. The auger capacity drops significantly with increased angle. Whereas the angle on the swing changes very little in comparison, so it is possible for the swing to overfeed the main auger.

Order of Operations

- 1: Lower swing from transport, Swing around to appropriate unloading position. Roughly perpendicular to auger. (The only limitation to placement is that clear retraction should be possible without hitting your tractor cab)
 - 2: Retract Xtend auger all they way.
 - 3: Drive truck in so that you are roughly 2 feet from the end of the hopper and stop roughly between the appropriate hoppers.
 - 4: Extend hopper under trailer (With Tip Down)
 - 5: Raise hopper tip slightly off the ground and swing to position roughly centered below appropriate chute.
 - 6: Lower hopper tip onto ground
 - 7: ENGAGE PTO on tractor or power unit.
 - 8: Unload until empty and close chute
 - 9: Raise hopper tip
 - 10: Swing to other chute.
 - 11: Lower hopper tip onto ground.
 - 12: Unload until empty and close chute.
 - 13: DISENGAGE PTO on tractor or power unit.
 - 12: Retract Xtend auger fully.
 - 13: Move next trailer or truck into place as appropriate.
- Back to Step 4.

The Xtend auger may be swung or retracted freely with the PTO running as long as the spline shaft at the top does not become disengaged. On the 16" Xtend there is 24" of free movement back from full extension. The end of free working travel is indicated by the "Rodono Xtend" Decal starting to disappear under the collector cover.

Xtend 16"

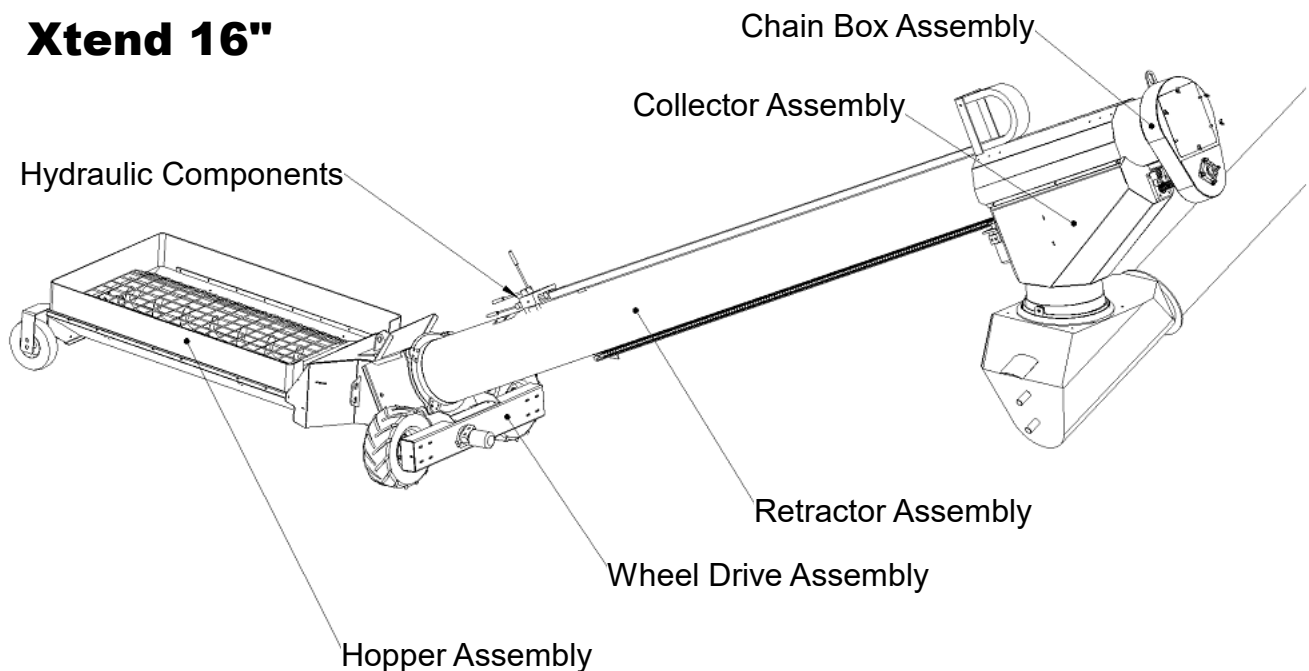

R16-A101 Retractor Assembly

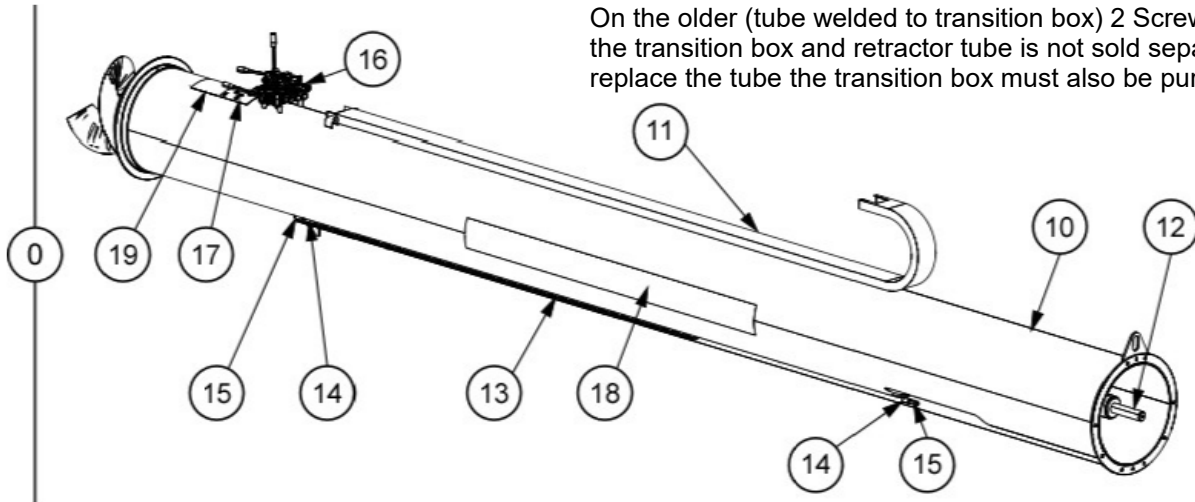

On the older (tube welded to transition box) 2 Screw Hopper the transition box and retractor tube is not sold separately. To replace the tube the transition box must also be purchased.

Item	Qty	Part #	Description
0	1	R16-A101	Complete Retractor Assembly
10	1	R16-A100	16" Welded Retractor
11	12'	IG200-10-125	Hose Carrier Chain
	4	H5CZ14.012	1/4" NC x 1/2" Bolt
	4	H5CZ14.034	1/4" NC x 3/4" Bolt
	4	LWZ14	1/4" Lock Washer
	4	NHCZ14	1/4" Nut
	1	IG2000-20	Carrier Bracket
	1	IG2000-21	Carrier Bracket
12	1	R16-A20	Main Screw Assembly
13	1	CHA 60-120.75	Rack Chain (tube)

Item	Qty	Part #	Description
14	2	CHA 60-1R-CO	Connecting Link
15	2	RP-2	Sliding Tightener
21	2	H8CZ516.214	5/16" NC x 2 1/4" Gr 8 Bolt
22	2	NH8CZ516	Nut 5/16" NC Gr 8
16	1	RC-A2	3 Spool Valve with fittings
21	3	H5CZ516.214	5/16" x 2 1/4" NC Grade 5 Bolts
	3	SLCC516	5/16" NC Stover Lock Nut
17	1	D3W	Valve Label
19	1	XW6	Caution Decal
18	2	XD1	Branding Decal
20	1	L7	Lifting Lug - 1 hole

This Transition Box couples with the current 3 screw hopper.

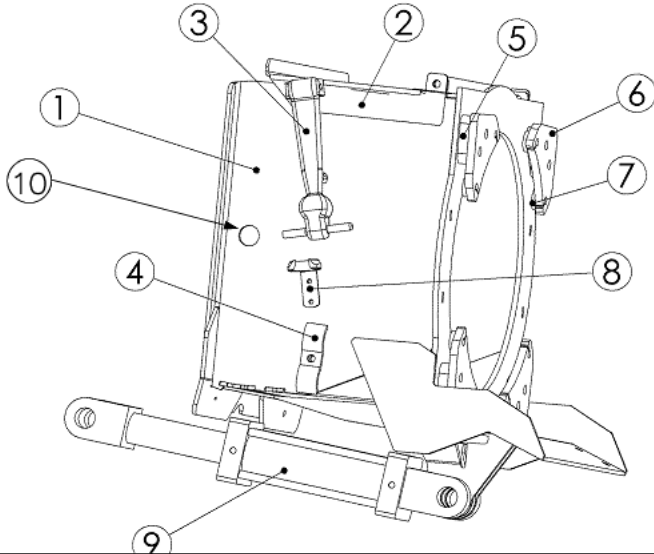

10	2	B75-100	Transition Box Pivot Bushing
21	2	H5CZ34.112	Bolt 3/4" x 1.5"
22	2	FWZC34	3/4" Flat Washer USS
23	2	LNC34	3/4" Nylon Lock Nut

Item	Qty	Part #	Description
0	1	R16-A501	Retractor Box Assembly
1	1	R16-A500	Welded Retractor Box Assembly
2	1	H16-524	Transition Lid Assembly
11	2	H5CZ38.1	Bolt 3/8" x 1 NC
13	2	LNC38	Nylon Lock Nut 3/8"
12	2	FWSAEZC38	SAE Flat Washer 3/8"
3	2	WJ208	Rubber Hood Latch
4	1	HC-1	Hose Clamp 2 Place
14	1	H5CZ516.114	5/16" NC x 1 1/4" Bolt
15	1	LNC516	Nylon Lock Nut 5/16" NC
5	4	R16-45	SwivelSpacerBlockLC
6	4	R16-534	LargeFlangeHolder
16	8	H8CZ38.134	3/8" NC x 1 3/4" GR8 Bolt
18	8	NH8CZ38	3/8" NC Nut Gr 8
17	8	LW838	3/8" Gr 8 Lock Washer
7	8	BW1-195	WearButton
8	2	WJ208	Hood Latch Catch
19	4	MPPS1024.58	Stainless Machine Screw
20	4	LN18.81024	Nylon Lock Nut
9	1	25TL04-112	4" Stroke Tie Rod Cylinder

* Not Shown- 3/8" Grade 8 Nut, SAE Flat Washer and Lock Washer X 4 to mount wheel drive

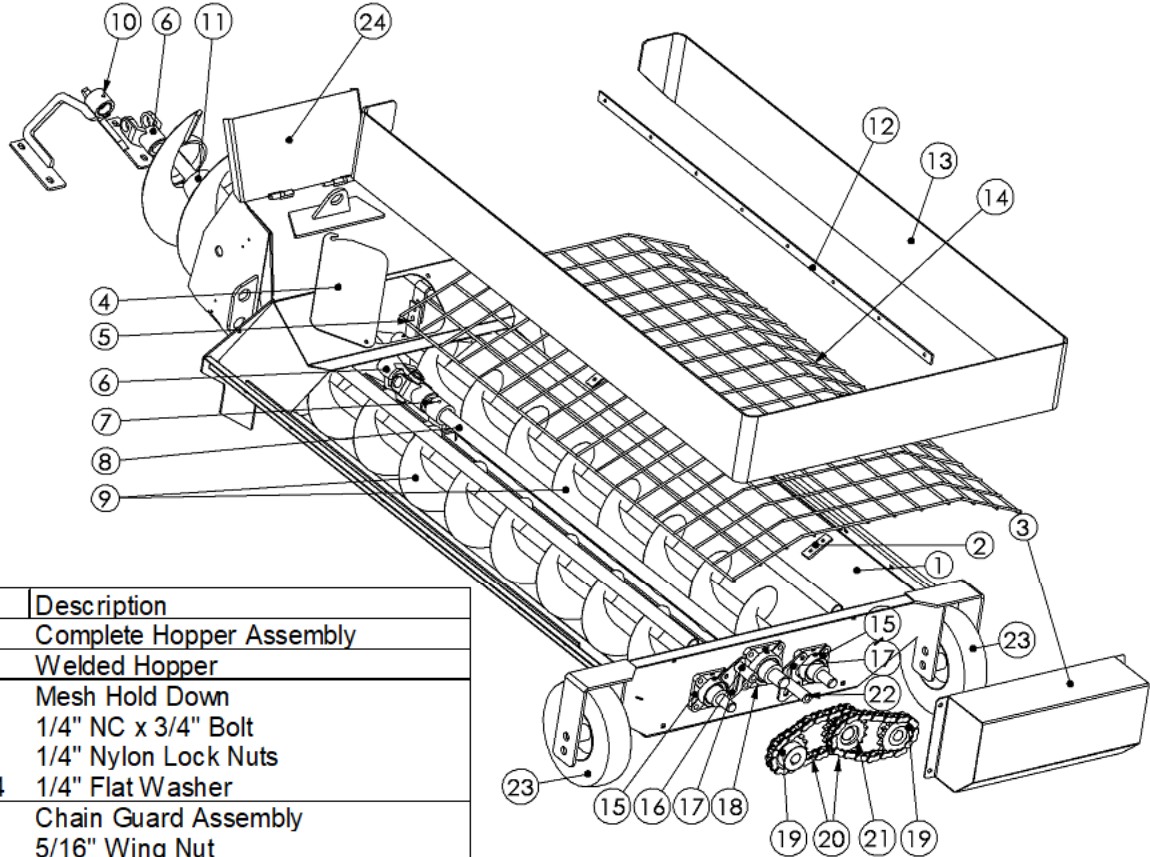

Item	Qty	Part #	Description
0	1	H16-A0	Complete Hopper Assembly
1	1	H16-A1	Welded Hopper
2	4	HC-4	Mesh Hold Down
	4	H5CZ14.034	1/4" NC x 3/4" Bolt
	4	LNC14	1/4" Nylon Lock Nuts
	4	FWSAEZC 14	1/4" Flat Washer
3	1	H16-21	Chain Guard Assembly
	4	NWCZ516	5/16" Wing Nut
4	1	HC-35	Transition Inspection Cover
	1	LNC516	5/16" Nylon Lock Nut
	1	FWZC516	Flatwasher USS 5/16"
	1	NWCZ516	5/16" Wing Nut
5	1	H16-A4	Feed Screw Bushing Hanger Right
	1	B150-1875-150	Bronze Bushing
	1	H13-A3	Feed Screw Bushing Hanger Left
	1	B150-1875-150	Bronze Bushing
	4	H5CZ38.114	Bolt 3/8" NC x 1 1/4"
	4	NHCZ38	Nut 3/8" NC
	4	FWSAEZC38	Flatwasher SAE 3/8"
	4	LWZ38	Lockwasher 3/8"
6	2	UA3524	U-Joint Assembly
	4	K375-125	Key 3/8" x 1 1/4"
7	1	H16-A33	Jack Shaft Bushing Assembly
	2	CBZ38.1	3/8" x 1" Carriage Bolt
	2	NHCZ38	Nut 3/8" NC
	2	LWZ38	Lockwasher 3/8"
8	1	H16-27	Hopper Jack Shaft
9	2	H16-A513	Feed Screw Assembly
10	1	H16-A2	Upper Transition Bushing Support
	1	B150-1875-150	Bronze Bushing
	4	H5CZ12.114	Bolt 1/2" NC x 1 1/4"
	4	FWSAEZC12	Flatwasher SAE 1/2"
	4	LNC12	Nylon Lock Nut 1/2" NC
11	1	H16-A22	Transition Screw SN 1301 to 1459
11	1	BR16-22	Transition Screw 2009-2012
12	2	H16-56	Skirt Retainer
	8	H5CZ14.034	1/4" NC x 3/4" Bolt
	8	LWZ14	Lockwasher 1/4"
	8	NHCZ14	Nut 1/4" NC

Item	Qty	Part #	Description
13	1	H16-57	Skirt
14	1	H16-MESH	Mesh
15	2	F208-24G	Bearing Assembly
	8	H5CZ12.112	Bolt 1/2" NC x 1 1/2"
	8	LWZ12	Lockwasher 1/2"
	8	NHCZ12	Nut 1/2" NC
16	2	H16-54	Chain Tensioner Bracket
17	1	T16B8L350	Chain Tensioner
	1	CBZ12.412	Carriage Bolt 1/2" NC 4 1/2"
	1	FWSAEZC12	Flatwasher SAE 1/2"
	1	LNC12	Nylon Lock Nut 1/2" NC
18	1	F208-24G	Bearing Assembly
	4	H5CZ12.112	Bolt 1/2" NC x 1 1/2"
	4	LWZ12	Lockwasher 1/2"
	4	NHCZ12	Nut 1/2" NC
19	2	WH24-SP6016X	Hub and Sprocket
	2	K375-125	Key 3/8" x 1 1/4"
20	2	CHA 60-26.75	Chain #60 x 26 3/4"
	2	CHA 60-1R-CO	Connecting Link
21	1	WDH24-SP6016X	Hub with Double Sprocket
	1	K375-125	Key 3/8" x 1 1/4"
22	1	T16B8L350	Chain Tensioner
	1	CBZ12.412	Carriage Bolt 1/2" NC 4 1/2"
	1	FWSAEZC12	Flatwasher SAE 1/2"
	1	LNC12	Nylon Lock Nut 1/2" NC
23	2	WS10x4	Solid Wheels
	2	H5CZ34.512	Bolt 3/4" NC x 5 1/2"
	2	LNC34	Nylon Lock Nut 3/4" NC
24	1	H16-A8	Transition Cover Assembly

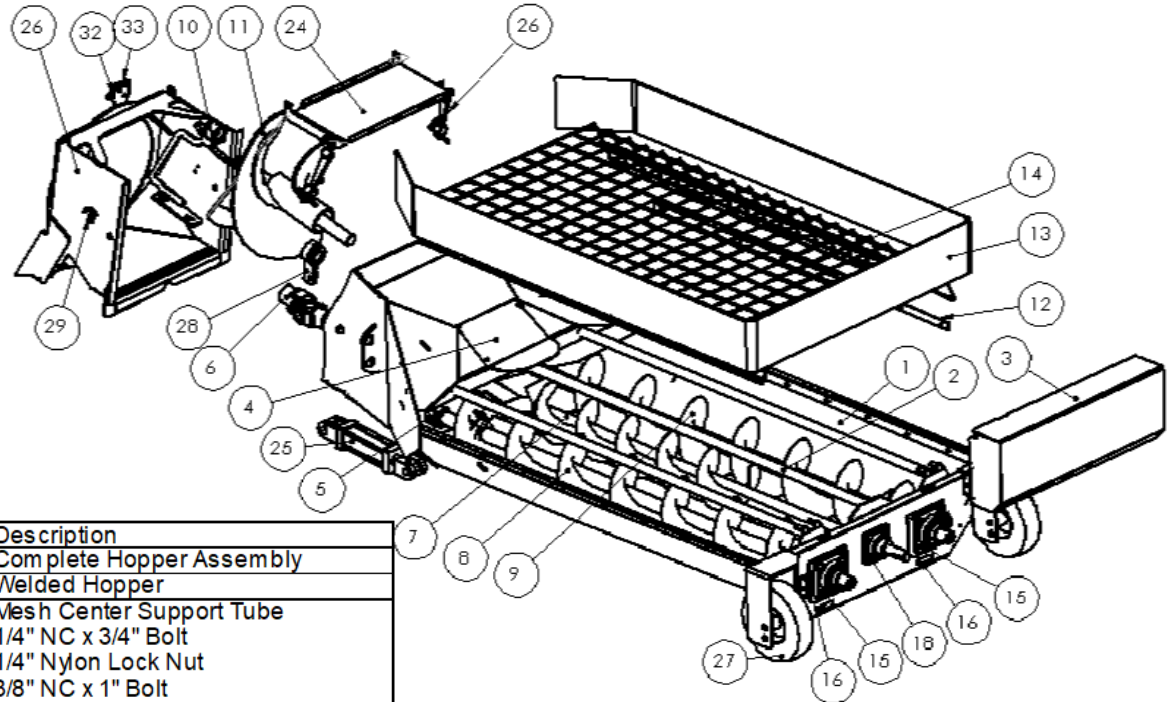

Item	Qty	Part #	Description
0	1	H16-A100	Complete Hopper Assembly
1	1	H16-A101	Welded Hopper
2	1	H16-113	Mesh Center Support Tube
	2	H5CZ14.034	1/4" NC x 3/4" Bolt
	2	LNC14	1/4" Nylon Lock Nut
	2	H5CZ38.1	3/8" NC x 1" Bolt
	2	LNC38	3/8" Nylon Lock Nut
3	1	H16-A120	Chain Guard Assembly
	2	NWCZ516	5/16" Wing Nut
4	1	HC-36	Transition Inspection Cover w bend
	1	LNCZ516	5/16" Nylon Lock Nut
	1	NWCZ516	5/16" Wing Nut
5	1	H16-A4	Feed Screw Bushing Hanger Right
	1	B150-1875-150	Bronze Bushing
	1	H16-A3	Feed Screw Bushing Hanger Left
	1	B150-1875-150	Bronze Bushing
	4	H5CZ716.114	7/16" NC x 1 1/4" Bolt
	4	NHCZ716	7/16" NC Nut
	4	LWZ716	7/16" Lockwasher
	4	FWSAEZC716	7/16" SAE Flatwasher
6	2	UA1224-20	U-Joint Assembly 1 1/2" x 1 1/4"
	1	K14-15	Key 1/4" x 1 1/2"
	1	K375-125	Key 3/8" x 1 1/4"
7	1	H16-SF71	Hopper Jack Shaft Screw 7" OD
8	1	H16-A113	Feed Screw Assem 9" RH w Groove
9	2	H16-A114	Feed Screw Assembly 9" LH
8	1	H16-27	Hopper Jack Shaft
9	2	H16-A513	Feed Screw Assembly
10	1	H16-A102	Upper Transition Bushing Support
	1	B150-1875-150	Bronze Bushing
	2	H5CZ12.114	1/2" NC x 1 1/4" Bolt
	2	H5CZ12.112	1/2" NC x 1 1/2" Bolt
	4	FWSAEZC12	1/2" SAE Flatwasher
	4	LNC12	1/2" NC Nylon Lock Nut
11	1	H16-A150	Transition Screw Assembly
12	2	H16-56	Skirt Retainer
13	1	H16-57	Rubber Skirt
	24	H5CZ14.034	1/4" NC x 3/4" Bolt
	24	SLCC14	1/4" Nylon Lock Nut
	6	FWZC14	1/4" Flat Washer
14	1	H16-MESH	Mesh
15	2	F208-24G	Bearing Assembly
	8	CBZ12.112	1/2" NC x 1 1/2" Carriage Bolt
	8	LWZ12	1/2" Lockwasher
	8	NHCZ12	1/2" NC Nut
16	2	H16-78	Chain Tensioner Plate
	2	CBZ516.112	Carriage Bolt 5/16" NC 1 1/2"
	1	SLCC516	5/16" NC Stover Lock Nut
	1	FWSAEZC12	Flatwasher SAE 1/2"
	1	LNC12	Nylon Lock Nut 1/2" NC

Item	Qty	Part #	Description
18	1	F206-20G	Bearing Assembly
	4	H5CZ716.112	7/16" NC x 1 1/2" Bolt
	4	LWZ716	7/16" Lockwasher
	4	NHCZ716	7/16" NC Nut
19	1	WH24-SP6021X	Hub and Sprocket
	1	K375-125	Key 3/8" x 1 1/4"
20	1	WDI24-21T	Idler Sprocket Assembly
	1 (HC-131 Idler Sprocket 21T)		
	2 (6910-2RS Bearings)		
	1 (H16-A132 Drive and Idler Hub with Sprocket)		
	1 22914 Snap Ring		
	1	K375-125	Key 3/8" x 1 1/4"
	1	5100-156	Snap Ring on Shaft
	1	HC-132	Countersunk Washer
	1	SFF38.112	Flat Head Socket Cap (2014(NC))
21	1	WDH20-SP6021X	Hub with Double Sprocket
	1	K14-15	Key 1/4" x 1 1/2"
22	1	CHA 60-31.375	Chain 31.375 OAL
	1	CHA 60-1R-CO	Connecting Link
	1	CHA 60-1R-OF	Offset Link
23	1	CHA 60-49.25	Chain 49.25 OAL
	1	CHA 60-1R-CO	Connecting Link
24	1	H16-A122	Transition Cover Assembly
	2	WJ208	Rubber Hold Down
	2	H5CZ516.034	5/16" NC x 3/4" Bolt
	2	SLCC516	5/16" NC Stover Lock Nut
	2	FWSAEZC516	5/16" SAE Flat Washer
25	1	25TL04-112	Cylinder
26	1	R16-A301	Transition Box
27	2	WS10x4	Solid Wheels
	2	H5CZ34.512	Bolt 3/4" NC x 5 1/2"
	2	LNCZ34	Nylon Lock Nut
28	1	H16-A104	Lower Trans Bushing Assembly
	2	H5CZ12.114	1/2" x 1 1/4" Bolt
	2	SLCC12	1/2" Stover Lock Nut
29	2	WJ208	Rubber Hold Down Catch
	4	SC18.81024.34	SS Socket Head Cap
	4	LN18.81024	Nylon Lock Nut 10-24
	4	FW1024	Flat Washer
30	1	UA3524	U-Joint Assembly 1 1/2"
	2	K375-125	Key 3/8" x 1 1/4"

See Page 9 for the transition box assembly that couples with this triple screw 2015+ hopper assembly.

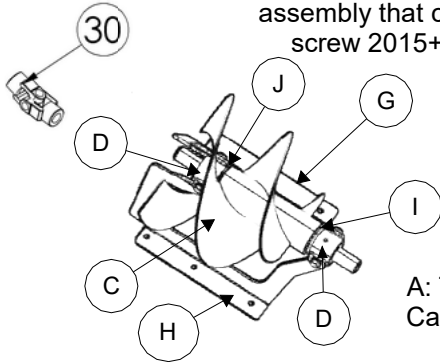

A: Transition Screw Cartridge Assembly

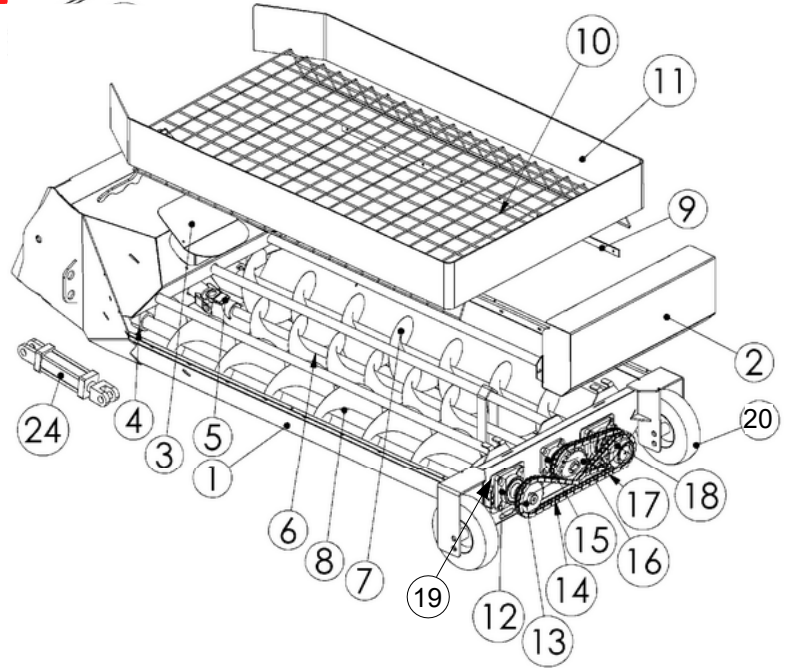

Item	Qty	Part #	Description
0	1	H16-A600	Complete Hopper Assembly
1	1	H16-A601	Welded Hopper
2	1	H16-A120	Chain Guard Assembly
	2	NWCZ516	5/16" Wing Nut
3	1	HC-36-16	Transition Inspection Cover w bend
	1	LNC516	5/16" Nylon Lock Nut
	1	FWSAEZC516	5/16" SAE Flatwasher
	1	NWCZ516	5/16" Wing Nut
4	1	H16-A300	Feed Screw Bushing Hanger Left
	1	B150-1875-150	Bronze Bushing
4	1	H16-A300	Feed Screw Bushing Hanger Right
	1	B150-1875-150	Bronze Bushing
	4	H5CZ716.112	7/16" NC x 1 1/2" Bolt
	4	NHCZ716	7/16" NC Nut
	4	LWZ716	7/16" Lockwasher
	8	FWSAEZC716	7/16" SAE Flatwasher
5	2	UA1224-20	U-Joint Assembly 1 1/2" x 1 1/4"
	1	K25-125	Key 1/4" x 1 1/4"
	1	K375-125	Key 3/8" x 1 1/4"
6	1	H16-SF71	Hopper Jack Shaft Screw 7" OD
7	1	H16-A513	Feed Screw Assem 9" RH w Groove
8	1	H16-A514	Feed Screw Assem 9" LH w Groove
9	2	H16-56	Skirt Retainer
10	1	H16-MESH	Mesh
11	1	H16-655	Rubber Skirt
	26	H5CZ14.034	1/4" NC x 3/4" Bolt
	24	SLCC14	1/4" Stover Nut
	10	FWZC14	1/4" Flat Washer
12	2	F208-24G	Bearing Assembly
	8	CBZ12.134	1/2" NC x 1 3/4" Carriage Bolt
	8	LWZ12	1/2" Lockwasher
	8	NHCZ12	1/2" NC Nut
13	1	WH24-SP6021X	Hub with Sprocket
	1	K375-125	Key 3/8" x 1 1/4"
	1	SE-150-050	External Snap Ring for 1 1/2" Shaft
14	1	CHA 60-49.25	Chain 49.25 OAL
	1	CHA-60-1R-OFF	Offset Link
	1	CHA 60-1R-CO	Connecting Link
15	1	F206-20G	Bearing Assembly
	4	H5CZ716.112	7/16" NC x 1 1/2" Bolt
	4	LWZ716	7/16" Lockwasher
	4	NHCZ716	7/16" NC Nut
16	1	WDH20-SP6021X	Hub with Double Sprocket
	1	K14-15	Key 1/4" x 1 1/2"
	1	SE-125-050	External Snap Ring for 1 1/4" Shaft
17	1	CHA 60-31.375	Chain 31.375 OAL

Item	Qty	Part #	Description
	1	CHA 60-1R-CO	Connecting Link
	1	CHA 60-1R-OFF	Offset Link
18	1	WDI24H-21T	Idler Sprocket Assembly
	(1)	WDI-732	Idler Sprocket 21T
	(1)	6210-2RSC3	Bearing
	(1)	WDI24-632	Drive and Idler Hub with Sprocket
	(1)	SIM-90-300	Internal Snap Ring
	(1)	SEM-50-200	External Snap Ring
	1	K375-125	Key 3/8" x 1 1/4"
	1	W0375-175	Heavy FW 0.375ID 1.75 OD
	1	LW838	3/8" Gr8 Lock Washer
	1	H8FZ38.1	3/8" x 1" NF Gr8 Bolt
	1	SE-150-050	External Snap Ring for 1 1/2" Shaft
19	2	H16-78	Chain Tensioner Plate
	2	CBZ516.112	Carriage Bolt 5/16"NC 1 1/2"
	2	SLCC516	5/16" NC Stover Lock Nut
24	1	25TL04-112	Cylinder (See page 16 for hydraulic assembly)
20	2	WS10x4	Solid Wheels
	2	H5CZ34.6	Bolt 3/4" NC x 5 1/2"
	2	LNC34	Nylon Lock Nut
30	1	UA3524	U-Joint Assembly 1 1/2"
	2	K375-125	Key 3/8" x 1 1/4"
A	1	H16-A502	Transition Screw Cartridge Assembly
C	1	H16-A150	Welded Transfer Screw Assembly
D	2	H16-A503	Bearing Assembly
	1	BT16-A24	Bushing Holder Assembly
	(1)	H16-559	Bushing Holder (Cartridge Style)
	(1)	B150-1875-150	Bronze Bushing 1 1/2" ID
	(1)	SEA 473228	Seal (CR 15142)
	(1)	GF 610	Grease Zerk
	(2)	H8CZ12.1	1/2" Gr8 x 1" Bolt
	(2)	FW8BLT12	1/2 SAE GR8 Flat Washer
	(2)	NLM12	Anti-Vibe Lock Washer 1/2"
G	1	H16-542	Transition Bushing Support Left
H	1	H16-543	Transition Bushing Support Right
I	1	H16-576	Thrust Washer (Bronze)
J	1	H16-577	Steel Spacer Washer - 16"

C16-A0 Collector Assembly

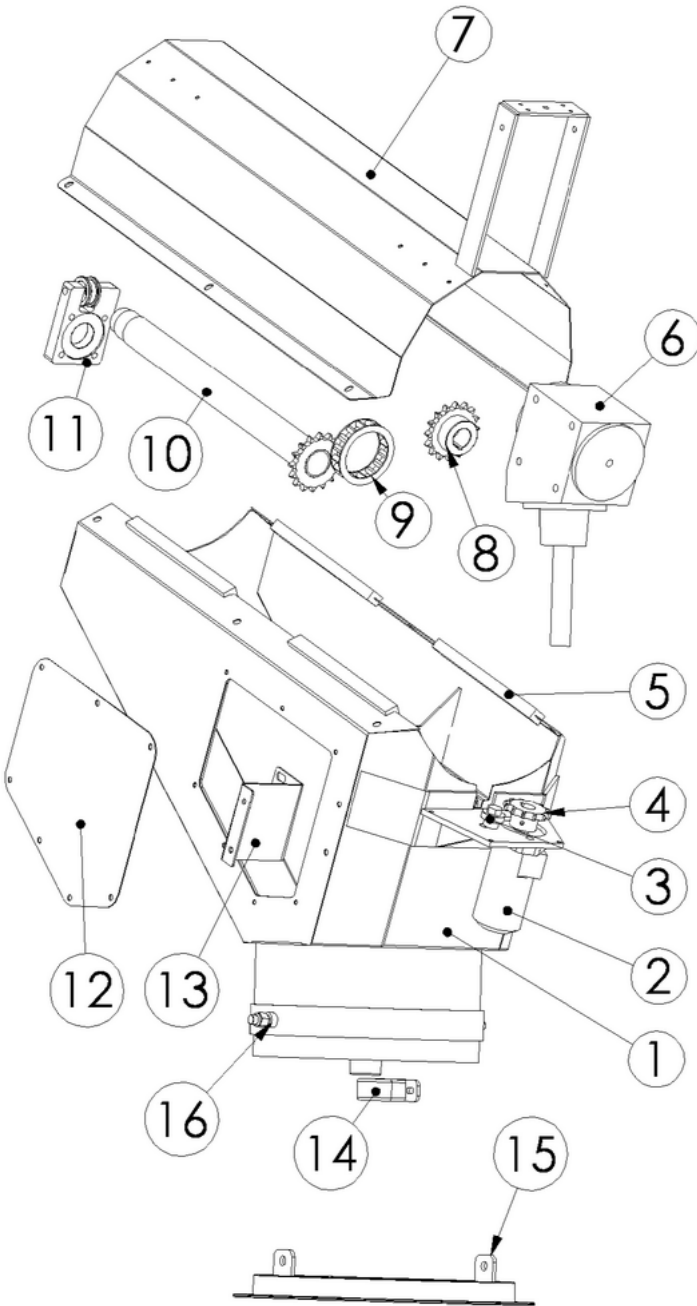

This Collector will only fit on Farm King 16" augers and uses the factory Farm King U-joint.

Item	Qty	Part #	Description	
0	1	C16-A0	Complete Collector Assembly	
1	1	C16-A1	Welded Collector Body	
2	1	ZBMR-200P4AllY5	Pinion Brake Motor	
3	1	6303-2RS	Pinion Roller	
	1	B3-0.625ID	Pinion Roller Spacer	
	1	H5CZ58.2	Bolt 5/8" NC	
	1	FWSAEZC58	Washer 5/8" SAE	
	1	LNC58	Lock Nut 5/8"	
4	1	WH16-SP6012W	Pinion Sprocket	
5	4	W1X0.75X0.5T	Wear Strip	
6	1	XGB16-LS	Gearbox 16 Long Shaft	
	4	H5CZ12.114	Bolts 1/2" NC x 1 1/4	
	4	FWZC12	Flat Washer 1/2"	
	4	LWZ12	LockWasher 1/2"	
7	1	C16-6	Collector Cover	
	6	H5CZ516.114	Bolt 5/16" NC x 1 1/4"	
	6	NHCZ516	Nut 5/16" NC	
8	1	H22-SP6016XSPC	Hub with Stop	
	1	K516-1	Key 5/16" x 1"	
9	1	CHA 60-2R-11.25	Double Chain	
	1	CHA 60-2R-CO	Connecting Link	
10	1	CC-A12-16RSI	Spline Tube Assembly 16	
11	1	CRF-1	Flange With Roller	
	1	CC-10	Track Roller	
	2	1621-2RS	Bearing for Track Roller	
	3	FWSAEZC12	Flatwasher 1/2" SAE	
	1	H5CZ12.5	Bolt 1/2" NC x 5"	
	1	LNC12	Nylon Lock Nut 1/2"	
	1	6209-2RS	Spline Tube Bearing	
	2	C-2	Collector Stop	
	2	SCC38.214	Socket Cap 3/8" x2 1/4"	
	2	LNC38	Nylon Lock Nut 3/8"	
	2	H5CZ38.134	Bolt 3/8" NC x 1 3/5"	
	2	LWZ38	Lockwasher 3/8"	
	2	NHCZ38	Nut 3/8" NC	
	12	1	C13-28	Door
		7	NWCZ516	Wing Nut
	13	1	C16-38	Gearbox Z Bracket
		2	H5CZ12.114	Bolts 1/2" NC x 1 1/4
		2	FWSAEZC12	SAE Flat Washer 1/2"
		2	LWZ12	LockWasher 1/2"
2		H5CZ38.1	Bolt 3/8" NC x 1"	
2		LWZ38	Lockwasher 3/8"	
2		FWSAEZC38	SAE Flat Washer 3/8"	
2	NHCZ38	Nut 3/8" NC		
14	1	PBW-28	Gearbox Lower Steady	
	2	H5CZ716.114	Bolt 7/16" NC x 1 1/4"	
	2	LWZ716	Lockwasher 7/16"	
2	NHCZ716	Nut 7/16" NC		
15	1	SRR*	Swing Ring (Model Dependant)	
16	2	SRB*	Swing Ring Spacer Bushing	
	2	SRF*	Fastener Set (Model Dependant)	

C16-A500 Collector Assembly (Dust Hose)

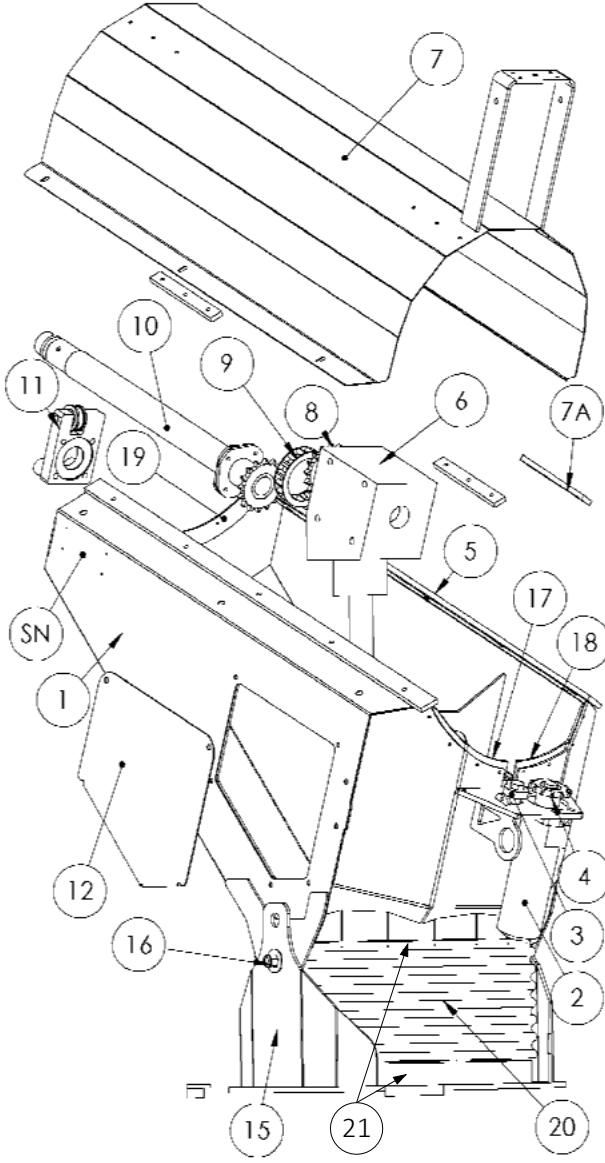

Item	Qty	Part #	Description	
0	1	C16-A500	Complete Collector Assembly	
1	1	C16-A501	Welded Collector Body	
	6	ALS4.518.150	Nutsert 5/16" NC	
2	1	ZBMR-200-P4AIIY5	Pinion Brake Motor	
	1	ZBMR-SK-UNIV	Brake Motor Seal Kit	
	2	SCC12.212	Socket Head Capscrew 1/2" x 2 1/2"	
	2	LWZ12	Lock Washer 1/2"	
	2	NHCZ12	Nut 1/2" NC	
3	1	6303-2RS	Pinion Roller	
	1	B3-0.625ID	Pinion Roller Spacer	
	1	H5CZ58.212	Bolt 5/8" NC 2 1/2"	
	1	FWSAEZC58	Washer 5/8" SAE	
	1	LNC58	Lock Nut 5/8"	
	1	SCC14.1	Socket Head Capscrew 1/4" x 1" NC	
4	1	LNC14	Nylon Lock Nut 1/4" NC	
	1	WH16-SP6012W	Pinion Sprocket	
5	4	UC14-663	Wear Strip	
	10	CBZ516.1	Carriage Bolt	
	10	FWZC516	Flat Washer 5/16" USS	
	10	SLCC516	Stover Lock Nut 5/16	
6	1	XGB16-R4	Gearbox Short Shaft 1 1/2" w Bolt Hole	
	4	H5CZ12.114	Bolts 1/2" NC x 1 1/4	
	4	FWZC12	Flat Washer 1/2"	
	4	LWZ12	Lock Washer 1/2"	
7	1	C16-A6	Collector Cover	
	4	W3	Collector Cover Wear Strip	
	12	SFC14.34	Socket Head Cap Screw Flat	
	12	LNC14	Nylon Lock Nut	
	6	H5CZ516.112	Bolt 5/16" NC x 1 1/2"	
	6	FWZC516	Flat Washer 5/16"	
8	6	NHCZ516	Nut 5/16" NC	
	1	H22-SP6016XSPC	Hub with Stop	
9	1	K516-1	Key 5/16" x 1"	
	1	CHA 60-2R-11.25	Double Chain	
10	1	CHA 60-2R-CO	Connecting Link	
	1	CC-A12-16RSI	Spline Tube Assembly 16	
11	2	FK/Mer	H5CZ516.112 Shear Bolt (Grade 5- 5/16" x 1 1/2")	
	2	BR/WF	H8CZ516.112 Shear Bolt (Grade 8- 5/16" x 1 1/2")	
	2	SLCC516	Stover Lock Nut 5/16	
12	1	CRF-A1	Flange With Roller Assembly	
	1	CRF-1	Roller Flange	
	1	CC-10	Track Roller	
	2	1621-2RS	Bearing for Track Roller	
	3	FWSAEZC12	Flatwasher 1/2" SAE	
	1	H5CZ12.5	Bolt 1/2" NC x 5"	
	1	LNC12	Nylon Lock Nut 1/2"	
	1	6209-2RSC3	Spline Tube Bearing	
	2	C-2	Collector Stop	
	2	SCC38.214	Socket Cap 3/8" x 2 1/4"	
13	2	LNC38	Nylon Lock Nut 3/8"	
	2	H5CZ38.134	Bolt 3/8" NC x 1 3/4"	
	2	LWZ38	Lockwasher 3/8"	
	2	NHCZ38	Nut 3/8" NC	
	1	C13-28	Door	
	7	NWCZ516	Wing Nut	
	15	1	C16-38	Gearbox Z Bracket
		1	C16-40	Gearbox Z Bracket B
		2	H5CZ12.114	Bolts 1/2" NC x 1 1/4
		2	FWZC12	Flat Washer 1/2"
2		LWZ12	Lock Washer 1/2"	
2		H5CZ38.1	Bolt 3/8" NC x 1"	
2		H5CZ38.114	Bolt 3/8" NC x 1 1/4"	
4		FWZC38	3/8 UCC Flatwasher	
4	LWZ38	Lockwasher 3/8"		
4	NHCZ38	Nut 3/8" NC		
22	1	SR16-A500	Brandt/Wheatheart Swing Ring	
	1	SR16-A560	Farm King Swing Ring	
	4	SR16-566	Brandt Spacer	
	4	SR16-657	Brandt Washer	

Item	Qty	Part #	Description
16	2	SRB-16-DH	Swing Ring Bushing
	2	CBZ58.134	Carriage Bolt 5/8"
	4	FWZC58	Flat Washer USS 5/8"
	2	LNC58	Lock Nut 5/8"
	1	C16-671	Pinion End Seal A
1	C16-672	Pinion End Seal B	
2	C16-670	ChainBoxEndSeal	
10	MPPS1024.34	Phillips SS 1024 Bolt 3/4"	
4	MPPS1024.58	Phillips SS 1024 Bolt 5/8"	
14	LN18.81024	SS Nylon Lock Nut 1024	
14	FWSAEZC14	1/4" SAE Flatwasher	
20		DH20-10	20" Duct Hose
		DH20-15	20" Duct Hose
		DH20-16	20" Duct Hose
		DH20-17	20" Duct Hose
		DH20-18	20" Duct Hose
2	DH20-GC	20" Dia SS Gear Clamp	
1	SNX	Serial Number Plate	
1	ACC67222	Manual Tube	
1	CC-10	Track Roller	

CB16-A0 Chainbox Assembly

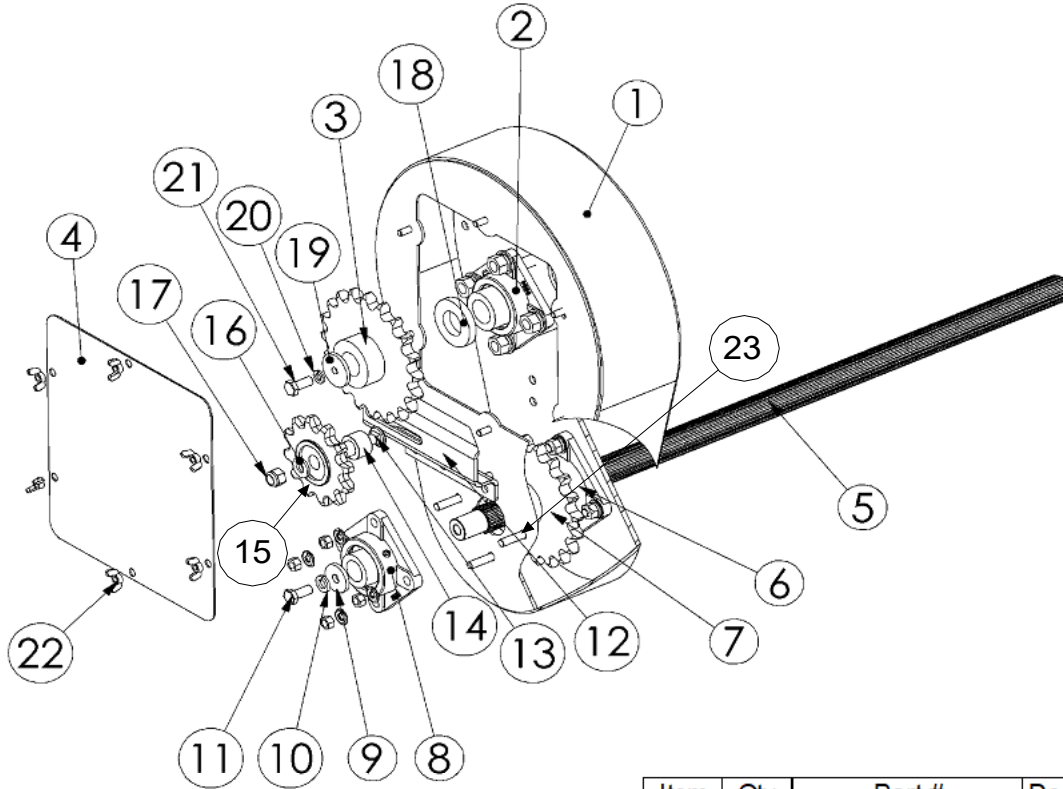

Item	Qty	Part #	Description
0	1	CB16-A0	Complete Chain Box Assem
1	1	CB16-A1	Welded Chainbox
0	1	CB16-A100	Chain Box Assem (L Flange)
1	1	CB16-A101	Welded Chainbox (L Flange)
4		H5CZ716.114	7/16" NC x 1 1/4" Bolt
3		H5CZ716.112	7/16" NC x 1 1/2" Bolt
7		LWZ716	7/16" Lockwasher
7		NHCZ716	7/16" NC Nut
2	1	F208-G1108KRRB	Bearing Assem w/Lock Collar
4		H5CZ12.112	1/2" NC x 1 1/2" Bolt
4		LWZ12	1/2" Lockwasher
4		NHCZ12	1/2" NC Nut
3	W	WH24-SP8020X	Hub with 8020X (Standard)
	F	WH24-SP8022X	Hub & 8022X (Farm King)
	M	WH24-SP8026X	Hub & 8026X (Meridian 14")
*	1	K375-125	3/8" x 1 1/4" Key
4	1	CB16-44	Chain Box Door
21	6	NWCZ516	5/16" Wing Nut
5	1	CB-35-16	Upper Spline Shaft
*	W	CHA 80-47	Drive Chain 47" with 8020
*	F	CHA 80-47	Drive Chain 47" with 8022
*	M	CHA 80-49	Drive Chain 49" with 8026
*	1	CHA 80-1R-CO	Connecting Link
*	F,M	CHA 80-1R-OF	Offset Link w/8022 and 8026
*		Not Shown	

Item	Qty	Part #	Description
6	1	F207-22UC	Bearing Assembly
23	4	H5CZ716.112	7/16" NC x 1 1/2" Bolt
	4	LWZ716	7/16" Lockwasher
	1	FWSAEZC716	7/16" SAE Flatwasher
	4	NHCZ716	7/16" NC Nut
7	1	WSH-SP8020X	Spline Hub w/ 8020 Sprocket
8	1	F206-18G	Bearing Assem w/Lock Collar
	4	H5CZ38.114	3/8" NC x 1 1/4" Bolts
	4	LWZ38	Lock Washers
	4	NHCZ38	3/8" NC Nut
9	1	FW.52X1.75X0.2	Heavy Washer
10	1	LWZ12	Lockwasher 1/2" GR8
11	1	H8FZ12.1	1/2" Fine x 1" Bolt
12	1	CBC-1	Tightener Z Bracket
13	1	CBZ12.212	1/2" x 2.5" Carriage Bolt
14	1	CB14-20	Tightener Spacer (2016+)
	1	CBC-2	Chain Tightener Spacer
15	1	ID80A12-3/4	Idler Sprocket (2016+)
	1	CTA-80-12	Chain Tensioner w bearings
16	1	FWSAEZC12	SAE Flatwasher 1/2"
17	1	LNC12	Nylon Lock Nut 1/2"
18	1	FW.4x1.5x.2	Heavy Washer
19	1	LWZ38	Lockwasher 3/8"
20	1	H5CZ38.1	3/8" NC x 1" Bolt
22	1	CBC-A76	Retainer Assembly with bolts
	1	GF 641	Grease Fitting - 1/4 - 28

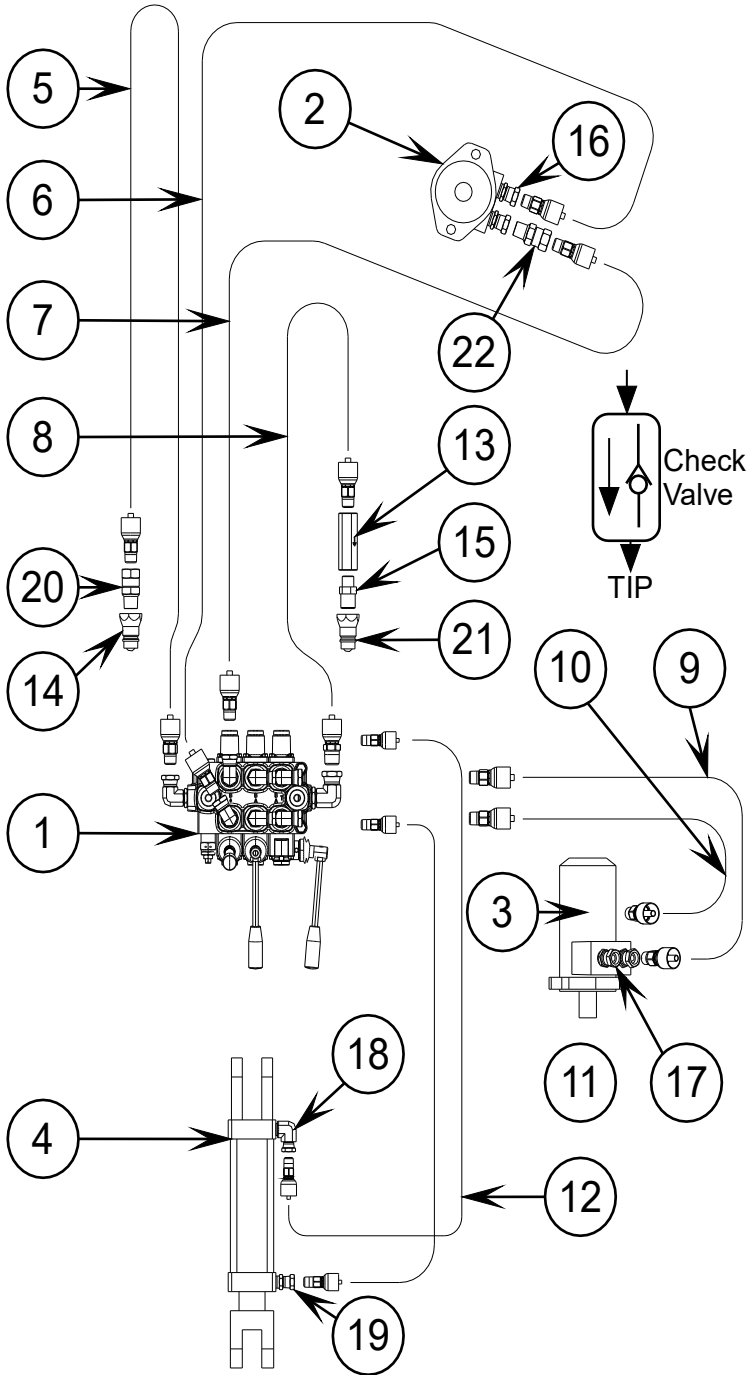

Item	Qty	Part #	Description	Connection
1	1	RC-A2	Valve Assembly (with fittings)	
2	1	ZBMR-200P4A11Y5	Pinion Motor (Brake Motor)	
3	1	BMPH-400P4A11Y9	Wheel Drive Motor	
4	1	25TL04-112	Tilt Cylinder (with pins)	
5	1	HYD-5	Hose Assembly	
	29'	WPH6-2	3/8" 2 wire hose	
	1	10143-8X6	1/2" NPT Hose End	Coupler
	1	10143-6X6	3/8" NPT Hose End	Valve
6	1	HYD-6	Hose Assembly	
	200"	WPH6-2	3/8" 2 wire hose	
	1	10143-6X6	3/8" NPT Hose End	Valve
	1	10143-6X6	3/8" NPT Hose End	Motor
7	1	HYD-6	Hose Assembly	
	200"	WPH6-2	3/8" 2 wire hose	
	1	10143-6X6	3/8" NPT Hose End	Valve
	1	10143-6X6	3/8" NPT Hose End	Motor
8	1	HYD-5	Hose Assembly	
	29'	WPH6-2	3/8" 2 wire hose	
	1	10143-8X6	1/2" NPT Hose End	Valve
	1	10143-6X6	3/8" NPT Hose End	Coupler
9	1	HYD13-9	Hose Assembly	Wheel Drive
	50"	WPH6-2	3/8" 2 wire hose	
	1	10143-6X6	3/8" NPT Hose End	Valve
	1	10143-6X6	3/8" NPT Hose End	Motor
10	1	HYD13-9	Hose Assembly	Wheel Drive
	50"	WPH6-2	3/8" 2 wire hose	
	1	10143-6X6	3/8" NPT Hose End	Valve
	1	10143-6X6	3/8" NPT Hose End	Motor
11	1	HYD13-11	Hose Assembly	Cylinder
	78"	WPH4-2	1/4" 2 wire hose	
	1	10143-4X4	1/4" NPT Hose End	Valve
	1	10143-4X4	1/4" NPT Hose End	Rod-End
12	1	HYD13-12	Hose Assembly	Cylinder
	81"	WPH4-2	1/4" 2 wire hose	
	1	10143-4X4	1/4" NPT Hose End	Valve
	1	10143-4X4	1/4" NPT Hose End	Clevis End
13	1	C-375-S-5	3/8" Check Valve	
14	1	8010-4MB	Pioneer Coupler Male	
15	1	0101-6X8	3/8" MNPT to 1/2" MNPT Adapter	
16	2	0507-10X6	#10 ORB M to 3/8" F Swivel	
17	2	0107-8X6	1/2" M to 3/8" F Swivel	
18	1	2107-6X4	3/8" M to 1/4" F Swivel	
19	1	0107-6X4	3/8" M to 1/4" F Swivel 90	
20	1	9205-08-08R.062	Orifice Fitting	
21	1	MANQAPN0808NPTF	Connect Under Pressure Coupler	
22	1	1404-06-06R.062	Orifice Fitting	

Seal Kits are Available ie (ZBMR-SK-UNIV, 25TL-SK, and BMPH-SK)

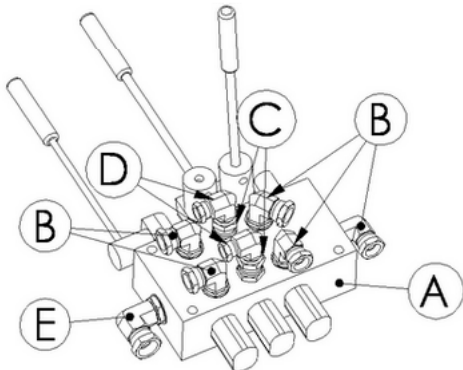

		RC-A2	Valve Assembly (with fittings)
Item	Qty	Part #	Description
A	1	VLV-3SP-WHDL	Valve with Handles
B	5	2507-8X6	#8 ORB to 3/8" FNPT 90 Swivel
C	2	0507-8X6	#8 ORB to 3/8" FNPT Swivel
D	2	2107-6X4	3/8" M to 1/4" F Swivel 90
E	1	2507-10X8	#10 ORB to 1/2" FNPT 90 Swivel

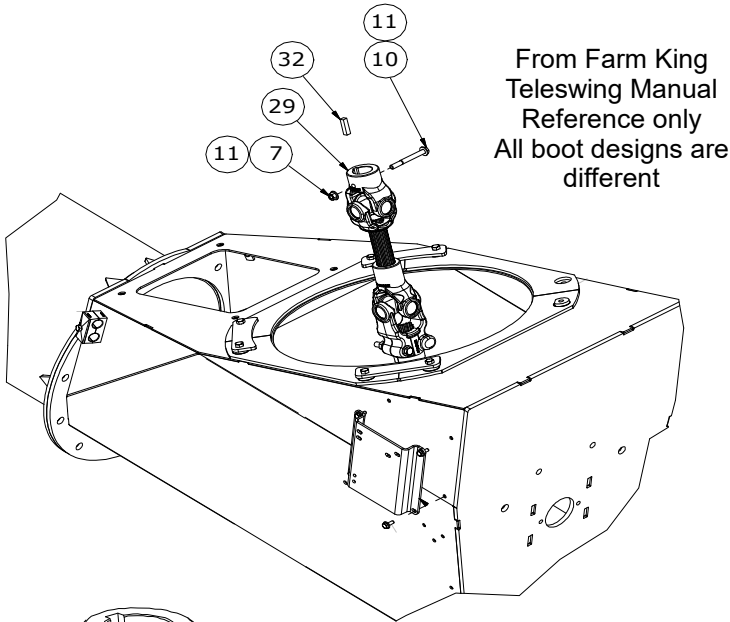

From Farm King Teleswing Manual Reference only All boot designs are different

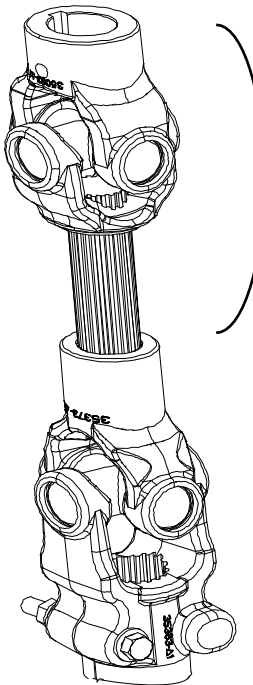

Upper U-Joint
 UA-35-CMD
 Pinned 1 1/2 Round Bore with Key by 20 Spline Male Shaft

Lower Farm King
 UA-WH35-FK16-Lower Female Spline x Splined FK Lower Gearbox

OR

Lower Wheatheart/Westfield
 UA-WH35-MKX16-Lower Female Spline x Bolted 1 1/2 Round Keyed Yoke-MKX 16 Lower Gearbox

Xtend 16 Driveline Options

This driveline setup is used on all 16" Xtend Swing Augers that have a dust hose style collector which was introduced in 2015 to coincide with the auger manufacturers switch to dust hoses.

It is also used in ALL Xtends used on the Wheatheart and Westfield 16" augers, regardless of year.

For Farm King- The Rodono Xtend 16 (White) and Farm King Teleswing (Red) 16 models from 2015 to current will use the same driveline, in 2021 Farm King started building the 16 Teleswing in house, so the part numbers will likely change in their manual to Farm King part numbers.

For Brandt- The Rodono Xtend 16 (White) and the Brandt Built EZ-Reach 16 (Blue) both use the factory U-Joint the same as a regular swing uses.

For Meridian 14" augers a 16" Xtend is used. The U-joint used is a UA-3524-1.70x20. This assembly is composed of a 35041-2278 spline yoke and a 35060-224 1.5" round yoke with a 200-3500 cross. Some early Meridian Xtends were shipped with a tall swing ring and a Farm King Driveline.

Brand (16's)	Year	Part	Description	Valid Xtends
Wheatheart X160	2014 to Current	UA-35-CMD	Upper Section with Male Spline Shaft	2015 and Newer
Wheatheart X160	2014 to Current	UA-WH35-MKX16-Lower	Lower Section Female Spline x Round Keyed	2015 and Newer
Westfield MKX 16	2014 to Current	UA-35-CMD	Upper Section with Male Spline Shaft	2015 and Newer
Westfield MKX 16	2014 to Current	UA-WH35-MKX16-Lower	Lower Section Female Spline x Round Keyed	2015 and Newer
Brandt	All	Factory	Use Brandt Factory U-Joint	2015 and Newer
Farm King 16	2014 and Prior	Factory	Use FK Factory U-Joint	2014 and Older
Farm King 16	2015 and Newer	UA-35-CMD	Upper Section with Male Spline Shaft	2015 and Newer
Farm King 16	2015 and Newer	UA-WH35-FK16-Lower	Lower Section Fem Spl x Clamp Spline	2015 and Newer
Meridian 14"	All	UA-3524-1.70x20	Rnd 1.5" x 1.75" 20 Spline Driveline	2015 and Newer

WD16U-A0 Wheel Drive Assembly

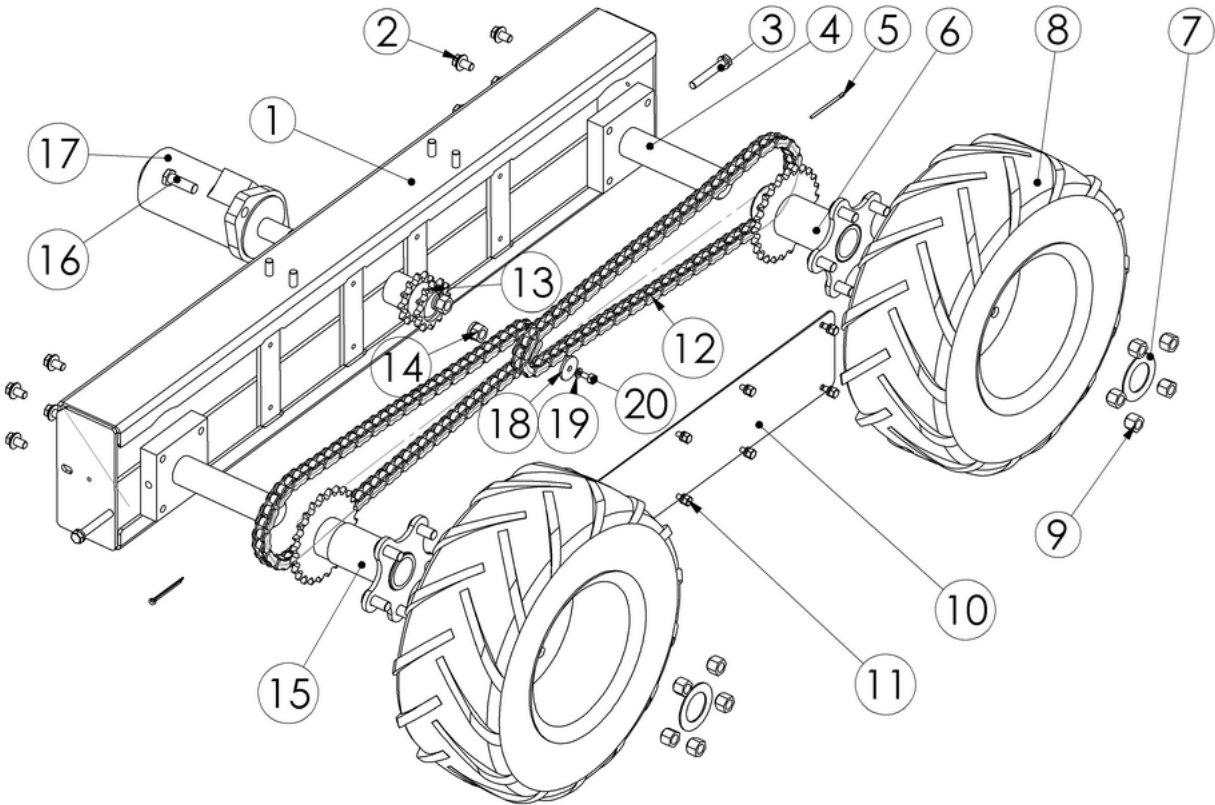

Item	Qty	Part #	Description
0	1	WD16U-A0	Wheel Drive Assembly
1	1	WD16U-A1	Welded Wheel Drive Frame
2	8	H8CZ38.034	Bolt 3/8" NC Gr 8 x 3/4"
	8	LW838	Lockwasher 3/8" Gr 8
	8	FW838	Flat Washer 3/8" Gr 8
3	2	H5CZ38.212	Bolt 3/8" NC Gr5 x 2 1/2"
	2	LWZ38	Lockwasher 3/8"
4	2	WD16-A5	Spindle
5	2	CP316.2	Cotter Pin
6	1	WD16-A3	Outer Rotating Hub
7	2	W150-200	Machine Washer
8	2	TSL16	Super Lug 16" Wheel & Tire
9	10	WB11	Wheel Nut
10	1	WD16U-14	Front Stiffener
11	8	LWZ14	Lock Washers - 1/4"
	8	H5CZ14.012	Bolt 1/4"NC x 1/2"

Item	Qty	Part #	Description
12	2	CHA 50-46	50 Roller Chain
	2	CHA 50-1R-CO	50 Connecting Link
13	1	WD16-A4	Dual Drive Hub
14	2	CBC-1	Nut 1/2" NC
	2	LWZ12	Lock Washers - 1/2"
15	1	WD16-A2	Inner Rotating Hub
16	2	H5CZ12.112	Bolt 1/2" NC x 1 1/2"
17	1	BMPH-400P4A11Y9	Wheel Drive Motor
	*	101-1032-009	Used for early models
18	1	WD16U-9	Machine Washer
19	2	LWZ14	Lock Washers - 1/4"
20	1	H5CZ14.034	Bolt 1/4" NC x 3/4"
Note:		Distance between sprocket and flange is 3.5" for the outer hub (6) and 4.5" for the inner hub (15).	

Maintenance

Greasing Schedule					
Decsription	Qty	Location	Frequency	Diagram	Item
U-Joints	1	Lower Hopper	80 hrs Operation	Hopper	5
	1	Upper Hopper	80 hrs Operation	Hopper	5
	1	Collector	80 hrs Operation	Swing Ring	6
Bushings	2	Hopper Feed Screw	8 hrs Operation	Hopper	5
	1	Hopper Jack Shaft	8 hrs Operation	Hopper	7
	1	Transition Screw	8 hrs Operation	Hopper	9
Bearings	2	Hopper Feed Screw	200 hrs Operation	Hopper	14
	1	Jack Shaft	200 hrs Operation	Hopper	15
	3	Chain Box Bearings	200 hrs Operation	Chain Box	2,6,8

Oil Schedule	
Chain Box	Greased at Factory -Add Grease through zerk - 80 hrs
Gearbox	Fill to Level SAE 90 Initially- Check and Maintain Level Yearly
Spline Shaft	Apply Light Oil- Monitor and Keep Clean and Lightly Oiled Apply Grease for Storage
Hopper Drive Chain	Apply oil when greasing - 80 hrs

Greasing	U-Joints	1 Pump	High Temp
Gearbox Oil	SAE 90		

Contacts:

Rodono Industries Ltd.
RR#1
Clive, Alberta
T0C 0Y0
Phone 403-784-3864
Fax 403-784-2402

email: contact@rodono.ca
website: www.rodono.ca

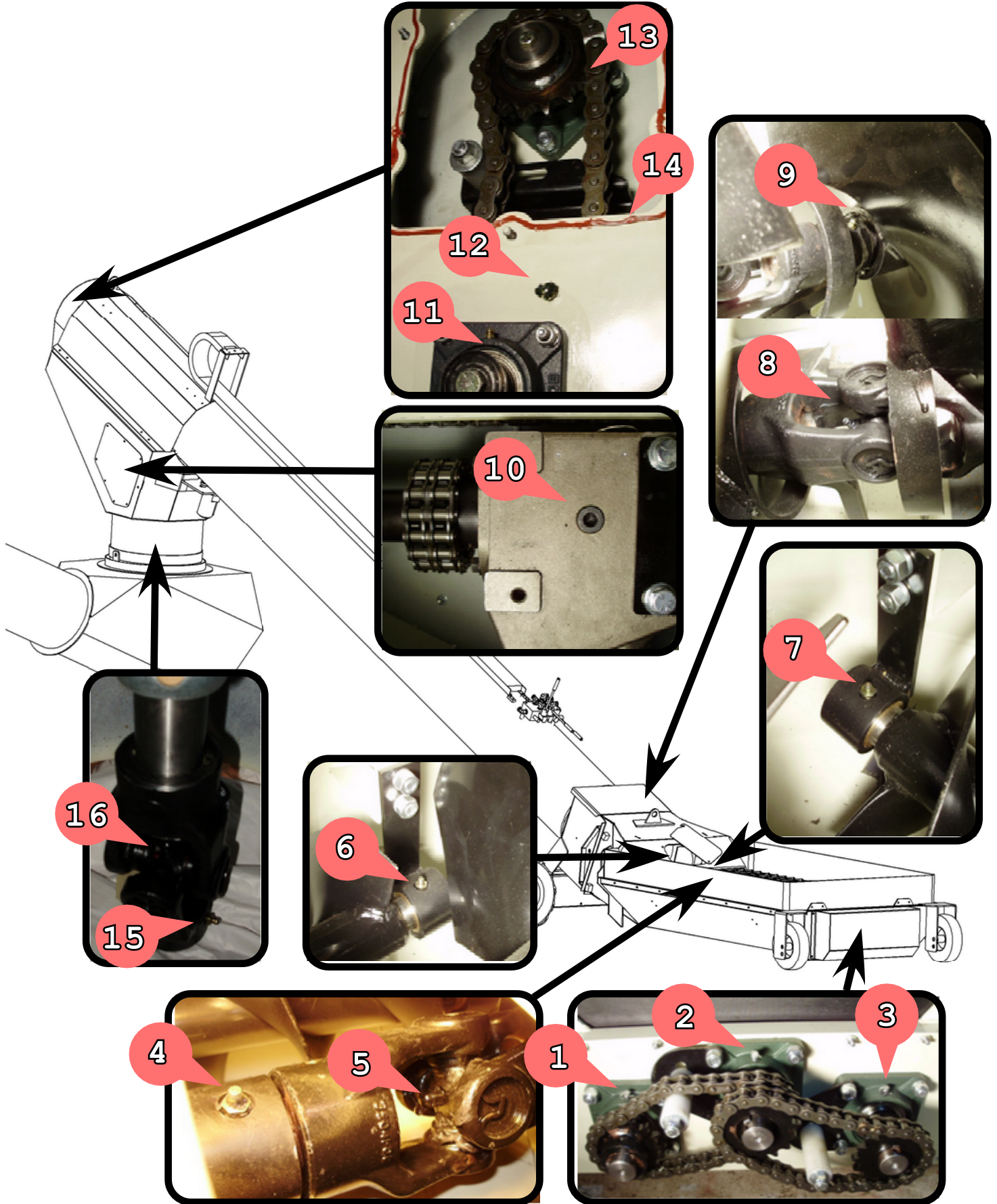



Farm King 16 Winch Mount

- Required on 1684
- Optional on 16104
 - Use bottom set of holes on 16104

Mounting Xtend 16 on Newer Farm King 16

- Plates are supplied by Rodono
 - Found in document tube
- Factory Spacers are used
- Driveline by Rodono



When mounting an older Farm King Auger (pre 2015), 8 special spacers will be supplied; 5/16" thick

Mounting Xtend 16 Meridian 14"

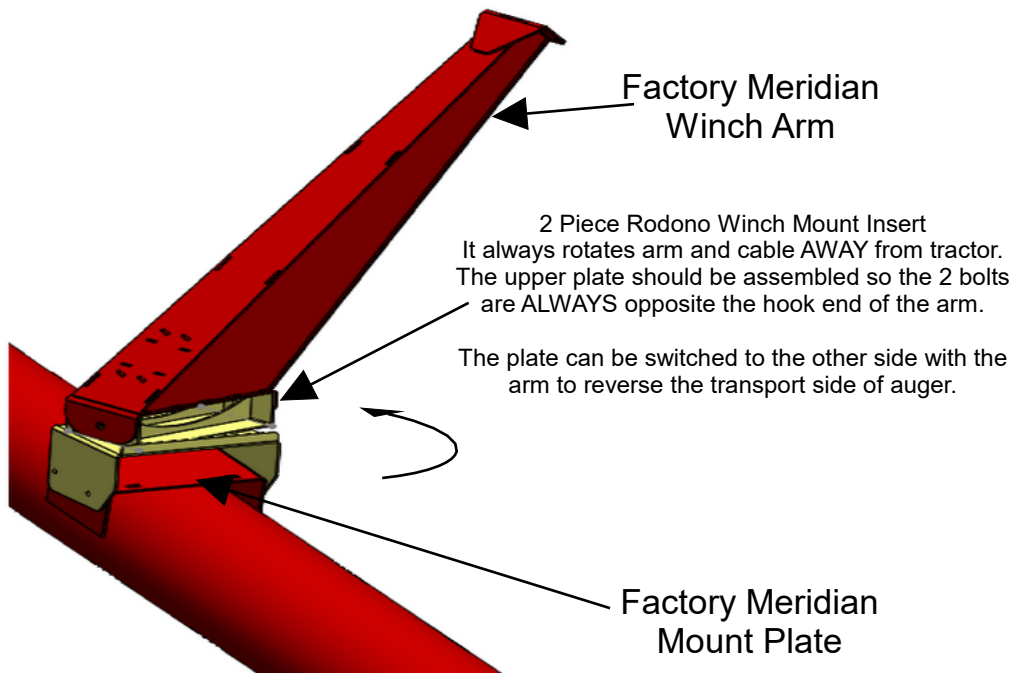

Connection Type:
1 1/2" Rnd x 1 3/4" Spline U-Joint- Bolted

Swing Ring:
Uses factory Meridian Hold down Hardware.

Winch:
Factory Meridian Winch arm and Rodono Winch Mount Insert

Winch Mount Angle Type:
Reversible but does not swivel the arm around.

Drive Speed:
Swing is slowed down in chain box 20 teeth to 26 teeth (If Auger is running 540 then swing is 415 rpm)

Bolts:
H8CZ12.2 - Qty 2
H8CZ12.112 - Qty 4
H5CZ1.212 - Qty 1